



SB, SBI, SBN 1, 3, 5, 10, 15, 20, 32, 45, 64, 90, 120, 150 series

立式多級離心式泵浦

60 Hz



STAIRS INDUSTRIAL CO., LTD.



頁數	產品數據
2	SB,SBI,SBN系列 效能範圍 60Hz
3	產品數據
4	產品數據
5	應用範圍
6	型號說明, 馬達數據
7	馬達數據, 機械軸封
8	最大運行壓力和入口壓力
9	結構材質
10	結構材質
11	結構材質

頁數	性能曲線 / 技術數據
12	SB, SBI, SBN 1
15	SB, SBI, SBN 3
18	SB, SBI, SBN 5
21	SB, SBI, SBN 10
24	SB, SBI, SBN 15
27	SB, SBI, SBN 20
30	SB, SBI, SBN 32
33	SB, SBI, SBN 45
36	SB, SBI, SBN 64
39	SB, SBI, SBN 90
42	SB, SBI, SBN 120
45	SB, SBI, SBN 150
48	輸送液體說明

效能範圍

Vertical Multistage Centrifugal In-line Pumps



STAIRS PUMPS

SB,SBI,SBN 系列 效能範圍 60Hz

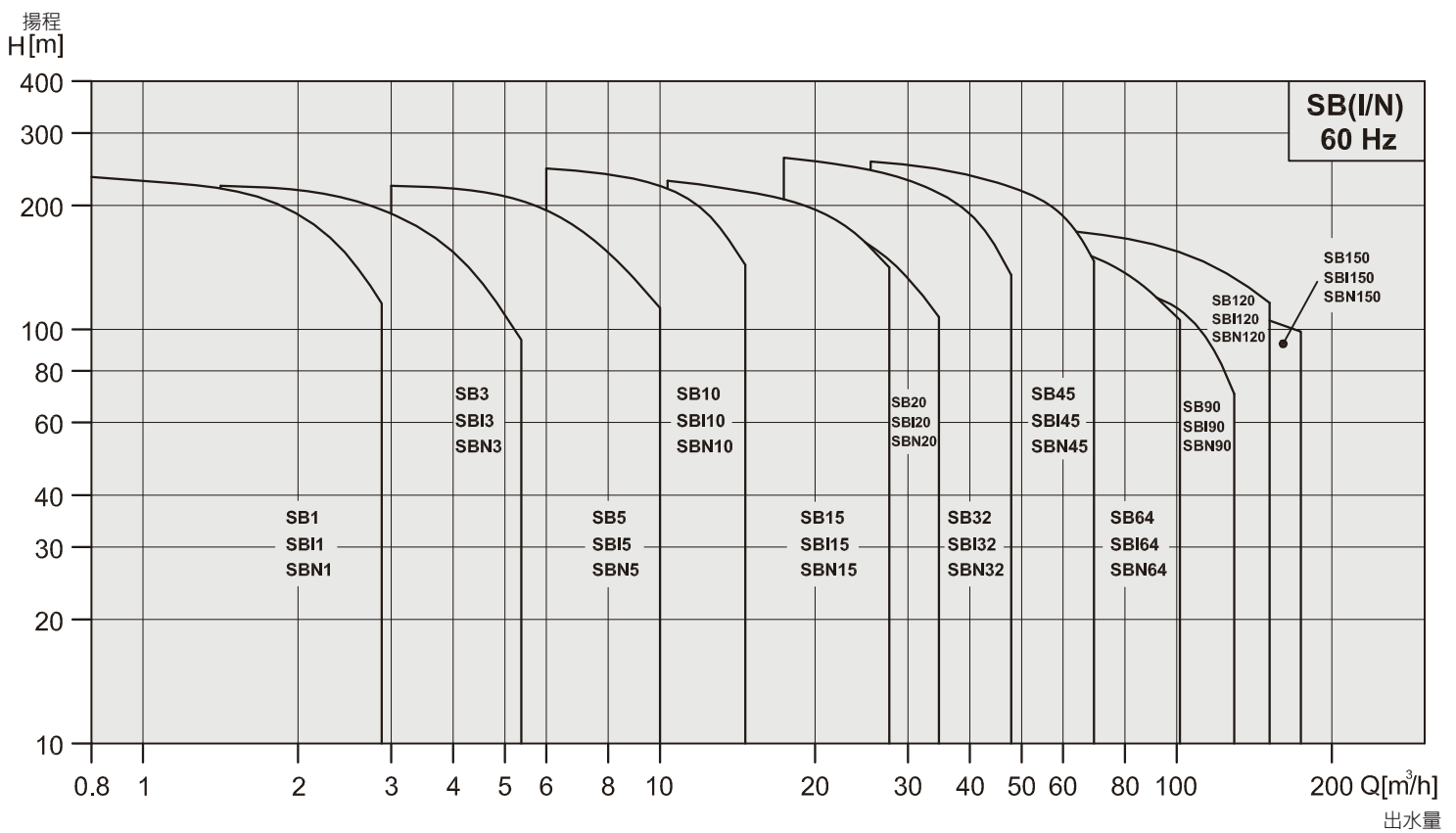

產品數據

Vertical Multistage Centrifugal In-line Pumps



STAIRS PUMPS

產品範圍	SB, SBI, SBN					
	1	3	5	10	15	20
60Hz						
標準流量 [m³/h]	1.2	3.6	6	12	18	24
流量範圍 [m³/h]	0.8-2.9	1.5-5.4	3-10	6-15.5	10.5-28	12.5-35
最大壓力 [bar]	23.5	23.3	23	24.5	23.5	20.5
溫度範圍 [°C]	-15 to +120 (-15 °C液體不可結冰, +120°C液體不可沸騰)					
電機功率 [kW]	0.37-3.0	0.37-4.0	0.55-7.5	0.75-11	1.5-18.5	2.2-18.5
規格						
SB: 鑄鐵 (液體在泵室內結冰有造成凍裂可能) 和不銹鋼 EN 1.4301/AISI 304	●	●	●	●	●	●
SBI: 不銹鋼 EN 1.4301/AISI 304	●	●	●	●	●	●
SBN: 不銹鋼 EN 1.4401/AISI 316	●	●	●	●	●	●
馬達						
供電電壓 3Ø [V/Hz] (波動範圍 ± 10%)	0.37-1.1 kW 220-255/380-440 V 60 Hz 1.5-7.5 kW 220-277/380-480 V 60 Hz From 11 kW 220/380/440 V 60 Hz					
絕緣等級	F					
防護等級	IP 55					
環境溫度	50°C					
SB 管路接口						
法蘭	DN 25/ DN 32	DN 25/ DN 32	DN 25/ DN 32	DN 40	DN 50	DN 50
SBI, SBN 管路接口						
法蘭	DN 25/ DN 32	DN 25/ DN 32	DN 25/ DN 32	DN 40	DN 50	DN 50
卡箍	R 1 ¹ / ₄ DN 32	R 1 ¹ / ₄ DN 32	R 1 ¹ / ₄ DN 32	R 2 DN50	R 2 DN50	R 2 DN50
機械軸封						
SiC / SiC	標準					
密封						
EPDM	標準					
Viton						

*法蘭標準:請參考圖紙尺寸

產品數據

Vertical Multistage Centrifugal In-line Pumps



STAIRS PUMPS

產品範圍	SB, SBI, SBN					
	32	45	64	90	120	150
60Hz						
標準流量 [m³/h]	38	54	77	108	140	180
流量範圍 [m³/h]	18-48	26-70	36-102	54-146	60-160	75-180
最大壓力 [bar]	27	26	17.8	15.9	18.5	15.3
溫度範圍 [°C]	-15 to +120 (-15 °C液體不可結冰, +120°C液體不可沸騰)					
電機功率 [kW]	2.2-30	5.5-45	7.5-45	11-45	18.5-75	18.5-75
規格						
SB: 鑄鐵 (液體在泵室內結冰有造成凍裂可能) 和不銹鋼 EN 1.4301/AISI 304	●	●	●	●	●	●
SBI: 不銹鋼 EN 1.4301/AISI 304	●	●	●	●	●	●
SBN: 不銹鋼 EN 1.4401/AISI 316	●	●	●	●	●	●
馬達						
供電電壓 3Ø [V/Hz] (波動範圍 ± 10%)	0.37-1.1 kW 220-255/380-440 V 60 Hz 1.5-7.5 kW 220-277/380-480 V 60 Hz From 11 kW 220/380/440 V 60 Hz					
絕緣等級	F					
防護等級	IP 55					
環境溫度	50°C					
SB 管路接口						
法蘭	DN 65	DN80	DN100	DN100	DN125	DN125
SBI, SBN 管路接口						
法蘭	DN 65	DN80	DN100	DN100	DN125	DN125
卡箍	N/A	N/A	N/A	N/A	N/A	N/A
機械軸封						
SiC / SiC	標準					
密封						
EPDM	標準					
Viton						

*法蘭標準:請參考圖紙尺寸

應用範圍

Vertical Multistage Centrifugal In-line Pumps



STAIRS PUMPS

產品介紹



SB, SBI, SBN 為非自吸立式多級離心泵。"管道"式泵浦結構設計，通過法蘭或卡箍將直接安裝在進出口同一水平線上且管徑相的平管路系統中，這種設計使泵浦的結構和更為"緊密配合"。

全系列泵浦配備卡匣式機械軸封，壽命長，易維護。

SB, SBI, SBN 泵浦有不同的規格和多樣的級數以滿足所需流量和壓力。

應用

供水和增壓

高層建築、飯店等增壓
主管網增壓、供水
工業給水增壓

灌溉和農業

土地灌溉
噴灌
滴灌

工業

高壓沖洗、清洗系統
汽車清洗設備
消防系統
流程水系統
機床(冷卻潤滑)

水處理

軟化、電解析系統
逆滲透(RO)系統
蒸餾系統
高壓過濾系統
超濾系統

輸送

鍋爐給水系統
制冷設備
冷卻空調系統
溫度控制系統
特殊輸送
工具機

型號說明

Vertical Multistage Centrifugal In-line Pumps



STAIRS PUMPS

型號說明

SB - 10 - 5 - 1 - S Q Q E

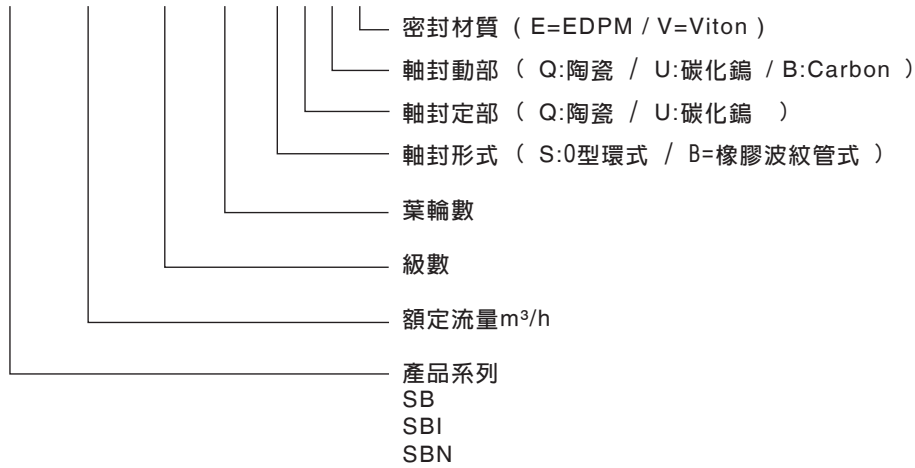

泵浦銘牌信息

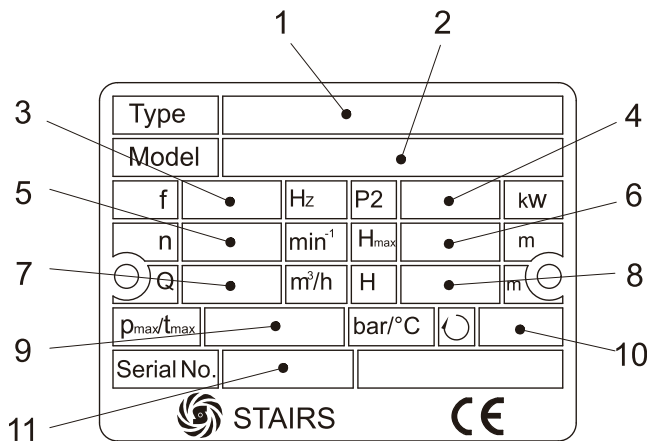

1. 泵浦型號-軸封型式
2. 泵浦型式
3. 頻率
4. 額定功率
5. 電機轉數
6. 最大揚程
7. 標準流量
8. 揚程範圍
9. 最大工作壓力
10. 旋轉方向
11. 生產序列號

馬達

●全封閉式，全鋁殼體，風冷，二極IEC標準馬達

●馬達數據

◎防護等級：IP55

◎絕緣等級：F

◎標準電壓：P2:0.37-7.5 KW:3x220-240/380-415V

P2:From 11KW 3x380-415V

●最高環境溫度：Max.+50°C

馬達數據

Vertical Multistage Centrifugal In-line Pumps



STAIRS PUMPS

馬達規格				額定電流[A]					
馬力	功率	Pole	法蘭型號	Frame	3-220V	3-255V	3-380V	3-440V	
0.5	0.37	2	B14	71A	1.7	1.7	1.0	1.0	
0.75	0.55			71B	2.4	2.4	1.4	1.4	
1.0	0.75			80A	3.1	3.1	1.8	1.8	
1.5	1.1			80B	4.5	4.2	2.6	2.4	
						3-220V	3-277V	3-380V	3-480V
2.0	1.5			90S	5.7	5.4	3.3	3.1	
3.0	2.2			90L	8.7	9.7	5.0	5.6	
4.0	3.0			100L	11.2	10.5	6.5	6.1	
5.5	4.0			112M	14.2	13.0	8.2	7.5	
7.5	5.5			B5	132S	18.5	15.8	10.7	9.1
10	7.5		132S		24.7	21.6	14.3	12.5	
15	11		160L		37.6	32.5	21.7	18.8	
20	15		160L		52.1	51.4	30.1	29.7	
					3-380V	3-480V	3-660V	3-830V	
4.0	3.0		B14	100L	6.5	6.1	3.8	3.5	
5.5	4.0			112M	8.4	7.2	4.8	4.2	
7.5	5.5		B5	132S	10.7	9.4	6.2	5.4	
10	7.5			132S	14.4	12.8	8.3	7.4	
15	11			160L	22.8	25.0	13.2	14.4	
20	15			160L	29.8	28.1	17.2	16.2	
					3-220V	3-380V	3-660V		
15	11	160M			36.0	20.8	12.0		
20	15	160M			49.0	28.4	16.3		
25	18.5	160L			59.9	34.7	20.0		
30	22	180M			71.3	41.3	23.8		
40	30	200L			96.5	55.8	32.2		
50	37	200L		118.1	68.4	39.4			
60	45	225M		142.7	82.6	47.6			
75	55	250M		174.4	101.0	58.1			
100	75	280S		236.3	136.8	78.8			

機械軸封

標準的卡匣式軸封由陶瓷/碳化鎢/EPDM或Viton組成。根據不同的應用選擇適用的軸封和橡膠。不同的材質的卡匣式機械軸封可快速更換，不需要特殊的工具或拆解泵浦。



軸封材質代號

內容		適用機種	SB/SBI/SBN	
			1/3/5/10/20 32/45/64/90	120 / 150
代號			0.5-60HP	75-100HP
軸封型式	S = O型環式	●	●	-----
	B = 橡膠波紋管式	-----	-----	●
定部+動部	QQ	●	●	●
	UU	選購	選購	-----
	QB	選購	選購	-----
	UB	選購	選購	-----
密封材質	E	●	●	●
	V	選購	選購	選購

● 標準配備

產品數據

Vertical Multistage Centrifugal In-line Pumps



STAIRS PUMPS

60Hz

級數	最大運行壓力	級數	最大入口壓力
SB, SBI, SBN 1			
2-27	25bar	2-25	10bar
		27	15bar
SB, SBI, SBN 3			
2-25	25bar	2-15	10bar
		17-25	15bar
SB, SBI, SBN 5			
2-24	25bar	2-9	10bar
		10-24	15bar
SB, SBI, SBN 10			
1-10	16bar	1-5	8bar
12-17	25bar	6-17	10bar
SB, SBI, SBN 15			
1-8	16bar	1-2	8bar
9-12	25bar	3-12	10bar
SB, SBI, SBN 20			
1-7	16bar	1	8bar
8-10	25bar	2-10	10bar
SB, SBI, SBN 32			
(1-1)-5	16bar	(1-1)-(2)	4bar
(6-2)-(10-2)	30bar	(3-2)-(6)	10bar
	30bar	(7-2)-(10-2)	15bar
SB, SBI, SBN 45			
(1-1)-4	16bar	(1-1)-1	4bar
(5-2)-7	30bar	(2-2)-3	10bar
		(4-2)-7	15bar
SB, SBI, SBN 64			
(1-1)-3	16bar	(1-1)	4bar
(4-2)-(5-2)	30bar	1-(2-1)	10bar
		2-(5-2)	15bar
SB, SBI, SBN 90			
(1-1)-3	16 bar	(1-1) - (2-2)	10bar
(4-2)	30 bar	(2-1) - (4-2)	15bar
SB, SBI, SBN 120			
1-(5-2)	30 bar	1	10bar
		(2-2)-(3-1)	15bar
		3-(5-2)	20bar
SB, SBI, SBN 150			
(1-1)-(4-2)	30 bar	(1-1)	10bar
		1-2	15bar
		(3-2)-(4-2)	20bar

*入口壓力+泵浦的閉閥壓力<最大運行壓力

結構材質

Vertical Multistage Centrifugal In-line Pumps



STAIRS PUMPS

示意圖

SB-1,3,5,10,15,20

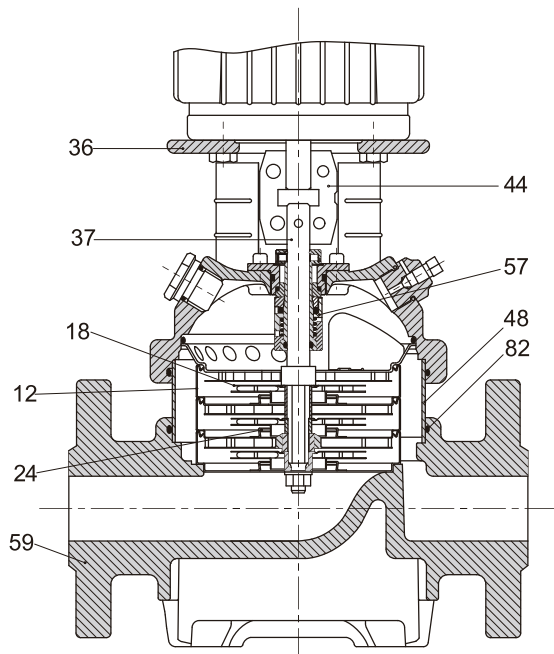

SBI(N)-1,3,5,10,15,20

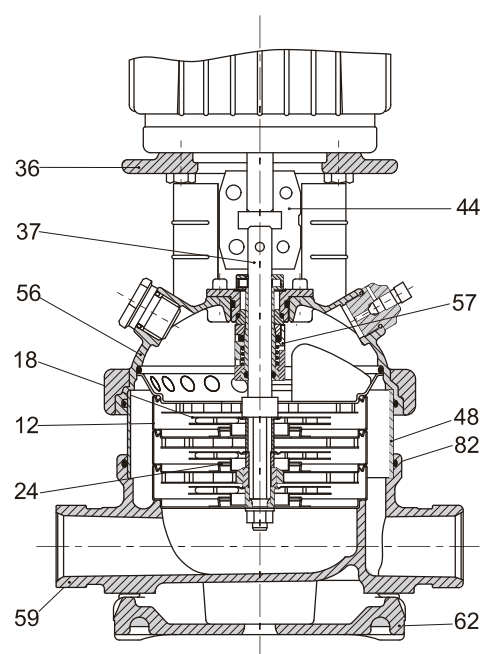

材質表

Pos.	名稱	材質	SB 1,3,5,10,15,20		SBI 1,3,5,10,15,20		SBN 1,3,5,10,15,20	
			標準		標準		標準	
			Europe	USA	Europe	USA	Europe	USA
36	泵浦中座	鑄鐵	EN-GJL-200	ASTM 25B	EN-GJS-450-10	ASTM 65-45-12	EN-GJS-450-10	ASTM 65-45-12
56	泵浦中座蓋	不銹鋼	N/A		1.4301	AISI 304	1.4401	AISI 316
18	葉輪	不銹鋼	1.4301	AISI 304	1.4301	AISI 304	1.4401	AISI 316
37	心軸	不銹鋼	1.4057	AISI 431	1.4057	AISI 431	1.4401	AISI 316
48	軸承外套	不銹鋼	1.4301	AISI 304	1.4301	AISI 304	1.4401	AISI 316
82	O型環 (泵浦管用)	EPDM						
12	導輪	不銹鋼	1.4301	AISI 304	1.4301	AISI 304	1.4401	AISI 316
24	頸圈	鐵氟龍						
59	泵浦底座	鑄鐵	EN-GJL-200	ASTM 25B	N/A			
	泵浦底座	不銹鋼	N/A		1.4301	AISI 304	1.4401	AISI 316
62	泵浦基座	鑄鐵	N/A		EN-GJL-200	ASTM 25B	EN-GJL-200	ASTM 25B
44	聯接器	Fe-Cu-C	SINT C11	MPIF FC0525	SINT C11	MPIF FC0525	SINT C11	MPIF FC0525
57	機械軸封	卡匣式						

結構材質

Vertical Multistage Centrifugal In-line Pumps



STAIRS PUMPS

示意圖

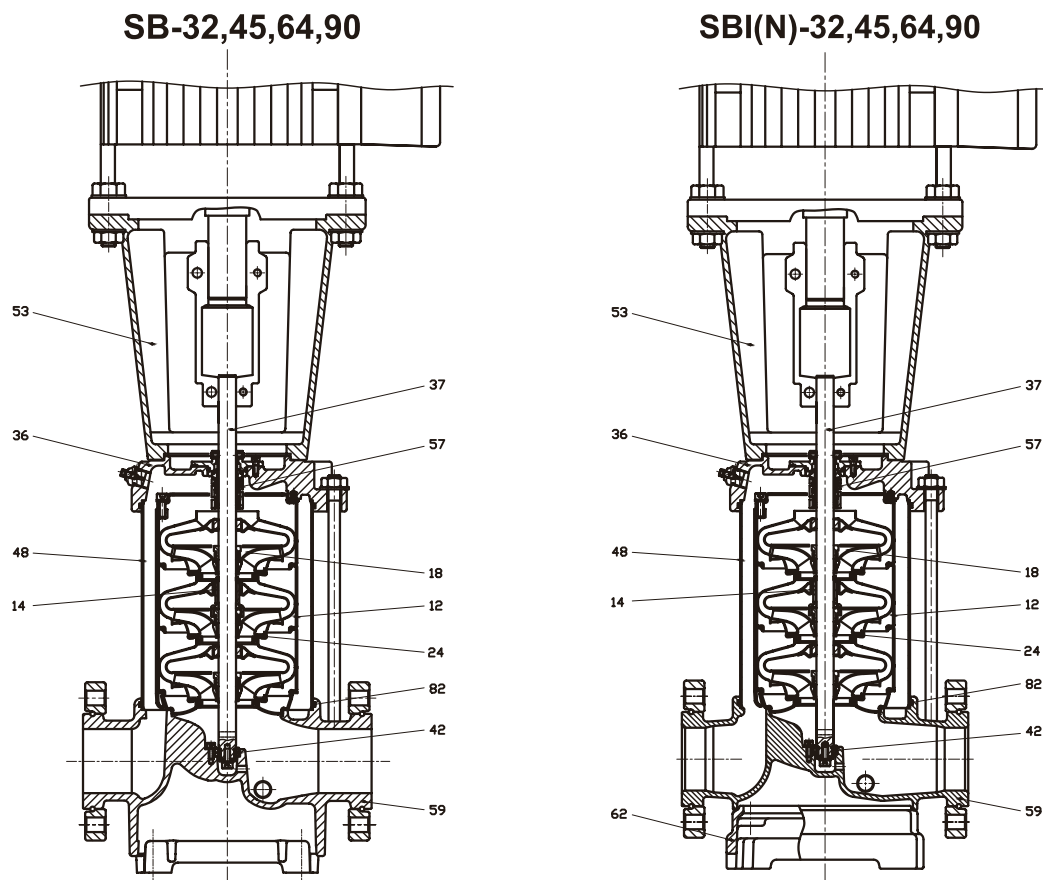

材質表

Pos.	名稱	材質	SB 32, 45, 64, 90		SBI 32, 45, 64, 90		SBN 32, 45, 64, 90	
			標準		標準		標準	
			Europe	USA	Europe	USA	Europe	USA
36	泵浦中座	鑄鐵	EN-GJL-250	ASTM 35B				
		不銹鋼			1.4301	AISI 304	1.4401	AISI 316
53	馬達聯接座	鑄鐵	EN-GJL-250	ASTM 35B	EN-GJL-250	ASTM 35B	EN-GJL-250	ASTM 35B
18	葉輪	不銹鋼	1.4301	AISI 304	1.4301	AISI 304	1.4401	AISI 316
37	心軸	不銹鋼	1.4057	AISI 431	1.4057	AISI 431	1.4401	AISI 316
48	軸承外套	不銹鋼	1.4301	AISI 304	1.4301	AISI 304	1.4401	AISI 316
82	O型環(泵浦管用)	EPDM						
12	導輪	不銹鋼	1.4301	AISI 304	1.4301	AISI 304	1.4401	AISI 316
24	頸圈	Carbon Fiber + POB + PTFE						
59	泵浦底座	鑄鐵	EN-GJL-250	ASTM 35B	N/A			
	泵浦底座	不銹鋼	N/A		1.4301	AISI 304	1.4401	AISI 316
62	泵浦基座	鑄鐵	N/A		EN-GJL-250	ASTM 35B	EN-GJL-250	ASTM 35B
57	機械軸封	卡匣式						
14	中間導輪軸承		Bronze				POB+Graphite+PTFE	
42	底部導輪軸承	碳化鎢/ 碳化鎢						

結構材質

Vertical Multistage Centrifugal In-line Pumps



STAIRS PUMPS

示意圖

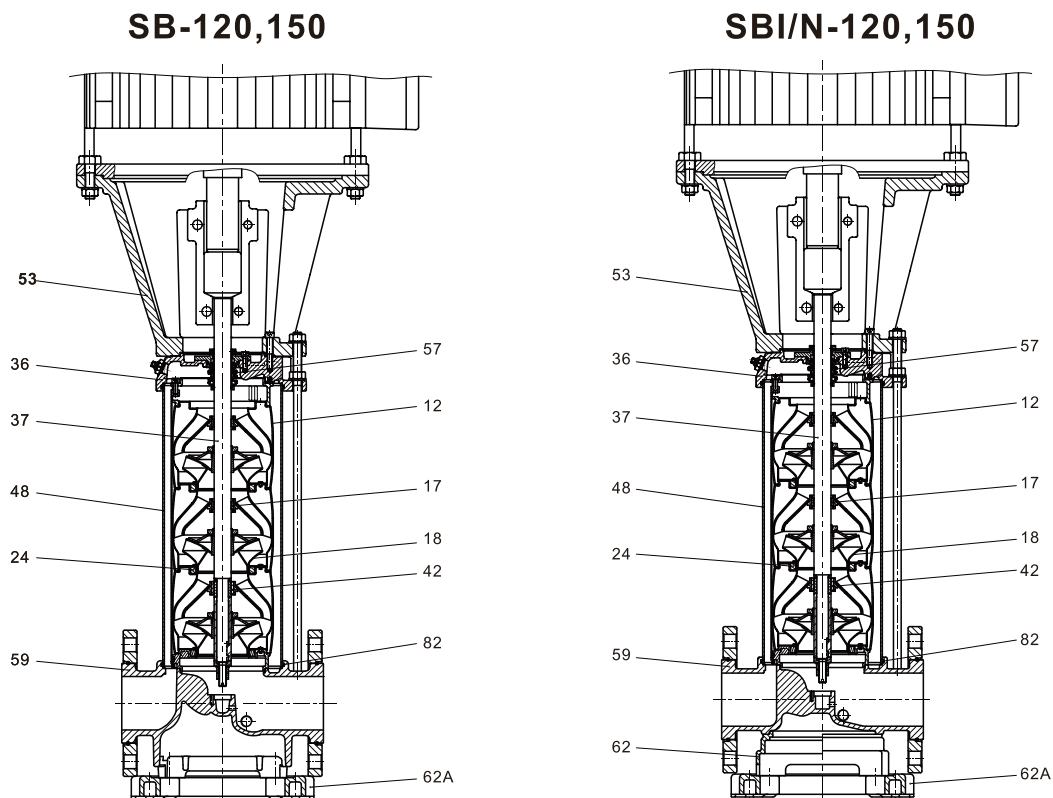

材質表

Pos.	名稱	材質	SB 120, 150		SBI 120, 150		SBN 120, 150	
			標準		標準		標準	
			Europe	USA	Europe	USA	Europe	USA
36	泵浦中座	鑄鐵	EN-GJL-250	ASTM 35B	N/A			
		不銹鋼	N/A		1.4301	AISI 304	1.4401	AISI 316
53	馬達連接座 (15HP~60HP)	鑄鐵	EN-GJL-250	ASTM 35B	EN-GJL-250	ASTM 35B	EN-GJL-250	ASTM 35B
	馬達連接座 (75HP~100HP)	鑄鐵	EN-GJS-450-10	ASTM 65-45-12	EN-GJS-450-10	ASTM 65-45-12	EN-GJS-450-10	ASTM 65-45-12
17	導輪軸承	鐵氟龍						
18	葉輪	不銹鋼	1.4301	AISI 304	1.4301	AISI 304	1.4401	AISI 316
37	心軸	不銹鋼	1.4057	AISI 431	1.4057	AISI 431	1.4401	AISI 316
48	軸承外套	不銹鋼	1.4301	AISI 304	1.4301	AISI 304	1.4401	AISI 316
82	O型環 (泵浦管用)	EPDM						
12	導輪	不銹鋼	1.4301	AISI 304	1.4301	AISI 304	1.4401	AISI 316
24	頸圈	鐵氟龍						
59	泵浦底座	鑄鐵	EN-GJL-250	ASTM 35B	N/A			
		不銹鋼	N/A		1.4301	AISI 304	1.4401	AISI 316
62	泵浦基座	鑄鐵	N/A		EN-GJS-450-10	ASTM 65-45-12	EN-GJS-450-10	ASTM 65-45-12
62A	泵浦基座	鑄鐵	EN-GJS-450-10	ASTM 65-45-12	EN-GJS-450-10	ASTM 65-45-12	EN-GJS-450-10	ASTM 65-45-12
57	機械軸封	卡匣式						
42	底部導輪軸承	陶瓷 / 陶瓷						

性能曲線-SB,SBI,SBN 1

Vertical Multistage Centrifugal In-line Pumps



STAIRS PUMPS

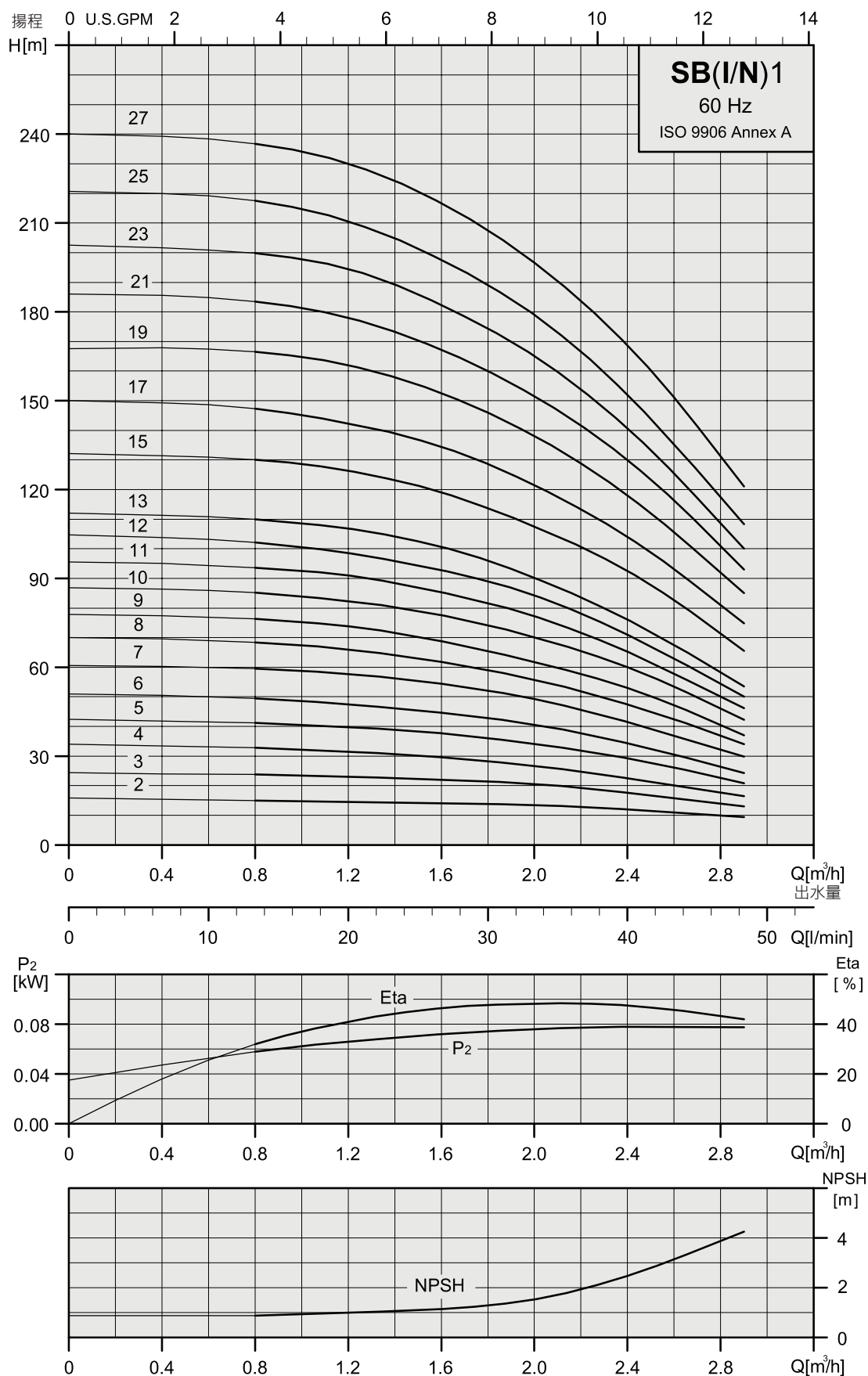

外型尺寸-SB1

Vertical Multistage Centrifugal In-line Pumps



STAIRS PUMPS

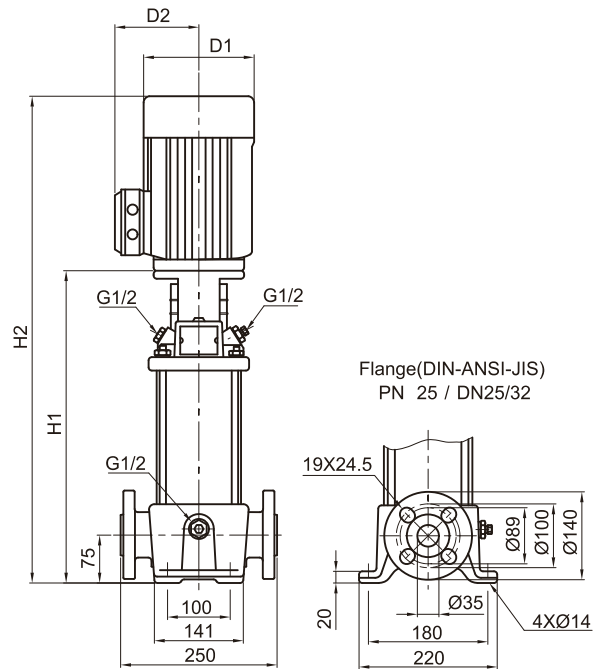

型號	馬達	SB 1				
		尺寸[mm]				重量 [kg]
		DIN flange		D1	D2	
		P ₂	H1			H2
功率						
SB1-2	0.37	279	474	141	115	23.4
SB1-3	0.37	279	474	141	115	23.4
SB1-4	0.37	297	492	141	115	23.8
SB1-5	0.55	315	510	141	115	24.7
SB1-6	0.55	333	528	141	115	25.0
SB1-7	0.75	357	592	141	115	27.5
SB1-8	0.75	375	610	141	115	27.9
SB1-9	0.75	393	628	141	115	28.3
SB1-10	1.1	411	646	141	115	29.8
SB1-11	1.1	429	664	141	115	30.2
SB1-12	1.1	447	682	141	115	30.5
SB1-13	1.1	465	700	141	115	30.9
SB1-15	1.5	517	808	177	141	40.3
SB1-17	1.5	553	844	177	141	41.0
SB1-19	2.2	589	880	177	141	44.6
SB1-21	2.2	625	916	177	141	45.3
SB1-23	2.2	661	952	177	141	46.1
SB1-25	2.2	697	988	177	141	46.8
SB1-27	3	737	1053	197	147	55.1

外型尺寸-SBI,SBN 1

Vertical Multistage Centrifugal In-line Pumps



STAIRS PUMPS

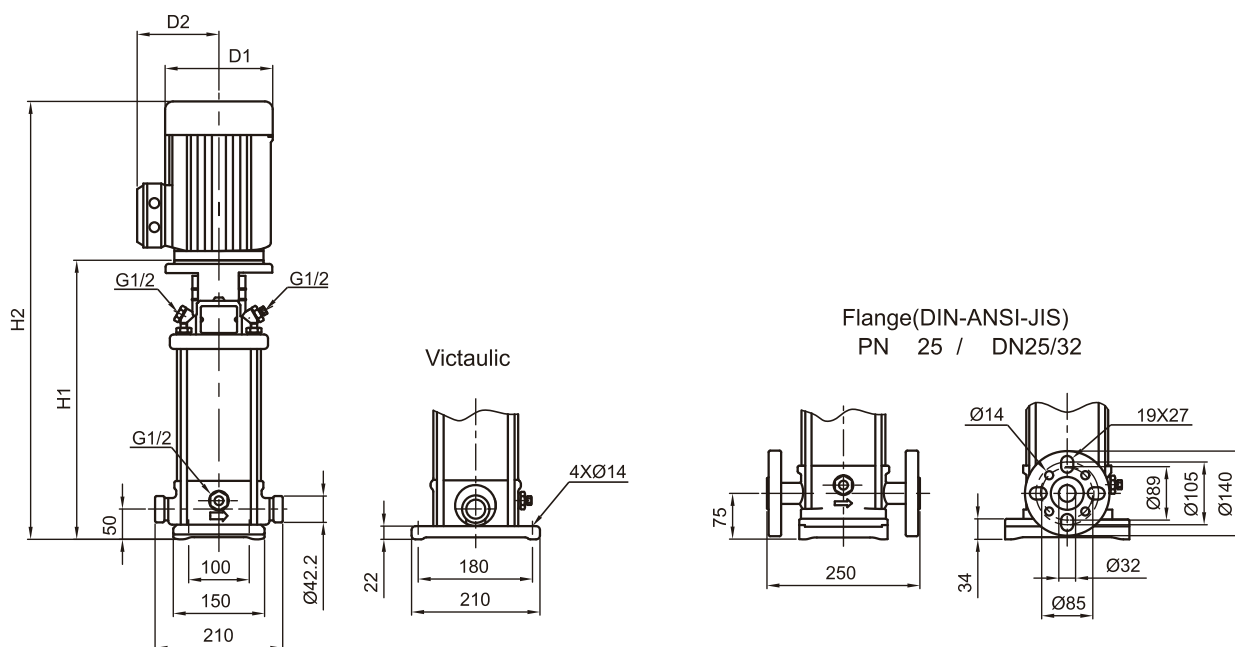

型號	馬達 P ₂ 功率	SBI , SBN 1							
		尺寸[mm]				重量[kg]			
		Victaulic		DIN flange		D1	D2	Victaulic	DIN flange
H1	H2	H1	H2						
SBI,SBN1-2	0.37	257	452	282	477	141	115	19.3	20.2
SBI,SBN1-3	0.37	257	452	282	477	141	115	19.3	20.3
SBI,SBN1-4	0.37	275	470	300	495	141	115	19.7	20.6
SBI,SBN1-5	0.55	293	488	318	513	141	115	20.6	21.5
SBI,SBN1-6	0.55	311	506	336	531	141	115	20.9	21.9
SBI,SBN1-7	0.75	335	570	360	595	141	115	23.3	24.2
SBI,SBN1-8	0.75	353	588	378	613	141	115	23.7	24.6
SBI,SBN1-9	0.75	371	606	396	631	141	115	24.0	25.0
SBI,SBN1-10	1.1	389	624	414	649	141	115	25.5	26.5
SBI,SBN1-11	1.1	407	642	432	667	141	115	25.9	26.9
SBI,SBN1-12	1.1	425	660	450	685	141	115	26.3	27.2
SBI,SBN1-13	1.1	443	678	468	703	141	115	26.7	27.6
SBI,SBN1-15	1.5	495	786	520	811	177	141	36.1	37.1
SBI,SBN1-17	1.5	531	822	556	847	177	141	36.9	37.8
SBI,SBN1-19	2.2	567	858	592	883	177	141	40.4	41.3
SBI,SBN1-21	2.2	603	894	628	919	177	141	41.2	42.1
SBI,SBN1-23	2.2	639	930	664	955	177	141	41.9	42.9
SBI,SBN1-25	2.2	675	966	700	991	177	141	42.6	43.6
SBI,SBN1-27	3	716	1032	741	1057	197	147	50.5	51.5

性能曲線-SB,SBI,SBN 3

Vertical Multistage Centrifugal In-line Pumps



STAIRS PUMPS

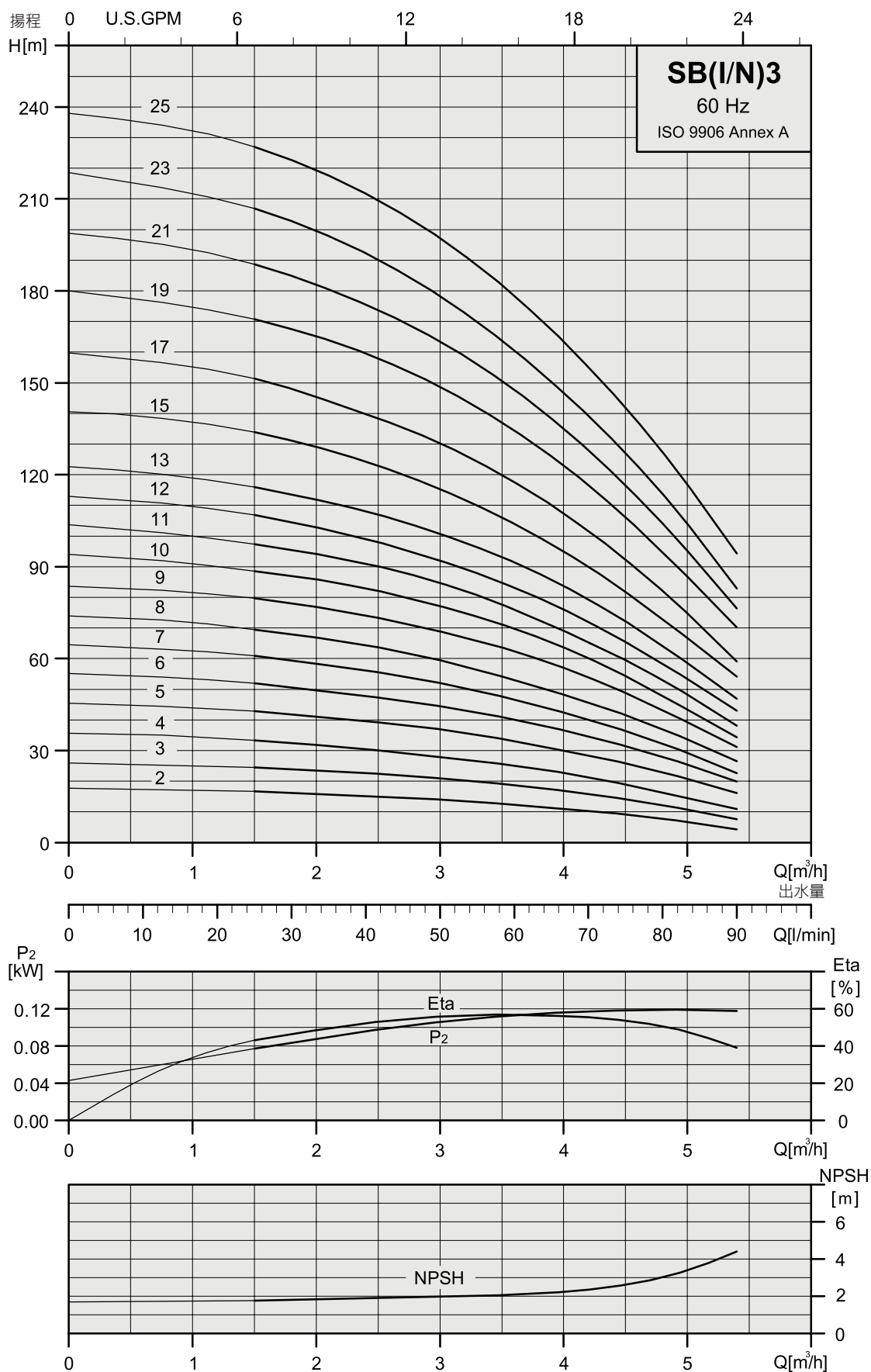

外型尺寸-SB 3

Vertical Multistage Centrifugal In-line Pumps



STAIRS PUMPS

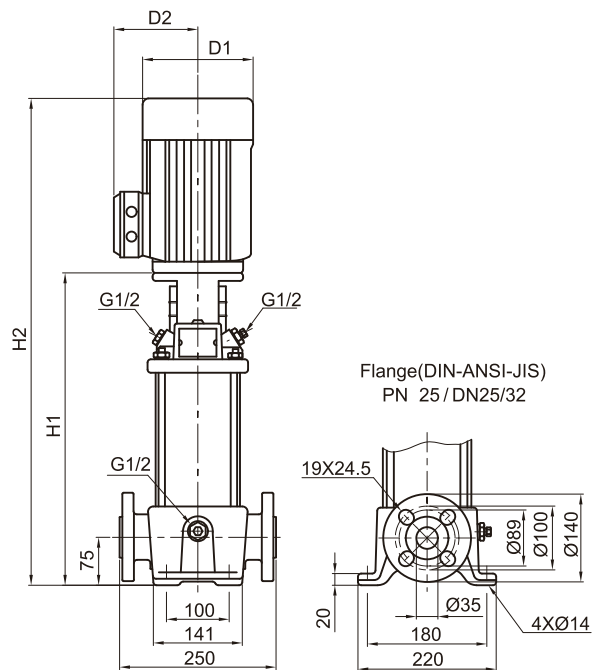

型號	馬達 P ₂ 功率	SB 3				
		尺寸[mm]				重量 [kg]
		DIN flange		D1	D2	
		H1	H2			
SB3-2	0.37	279	474	141	115	23.4
SB3-3	0.55	279	474	141	115	23.9
SB3-4	0.55	297	492	141	115	24.3
SB3-5	0.75	321	556	141	115	26.8
SB3-6	1.1	339	574	141	115	28.3
SB3-7	1.1	357	592	141	115	28.7
SB3-8	1.1	375	610	141	115	29.0
SB3-9	1.5	409	700	177	141	38.1
SB3-10	1.5	427	718	177	141	38.5
SB3-11	1.5	445	736	177	141	38.9
SB3-12	2.2	463	754	177	141	42.0
SB3-13	2.2	481	772	177	141	42.4
SB3-15	2.2	517	808	177	141	43.1
SB3-17	2.2	553	844	177	141	43.8
SB3-19	3	593	909	197	147	52.1
SB3-21	3	629	945	197	147	52.8
SB3-23	3	665	981	197	147	53.6
SB3-25	4	701	1027	220	161	57.7

外型尺寸-SBI,SBN 3

Vertical Multistage Centrifugal In-line Pumps



STAIRS PUMPS

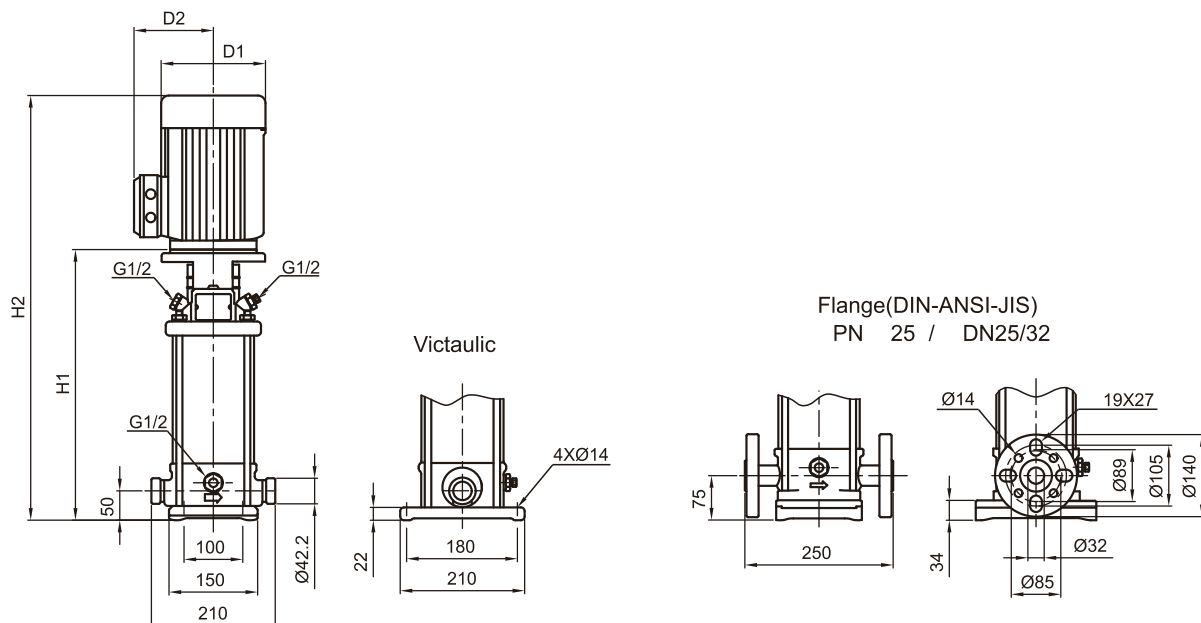

型號	馬達 P ₂ 功率	SBI , SBN 3							
		尺寸[mm]						重量[kg]	
		Victaulic		DIN flange		D1	D2	Victaulic	DIN flange
		H1	H2	H1	H2				
SBI,SBN3-2	0.37	257	452	282	477	141	115	19.3	20.2
SBI,SBN3-3	0.55	257	452	282	477	141	115	19.8	20.8
SBI,SBN3-4	0.55	275	470	300	495	141	115	20.2	21.1
SBI,SBN3-5	0.75	299	534	324	559	141	115	22.6	23.5
SBI,SBN3-6	1.1	317	552	342	577	141	115	24.1	25.0
SBI,SBN3-7	1.1	335	570	360	595	141	115	24.4	25.4
SBI,SBN3-8	1.1	353	588	378	613	141	115	24.8	25.7
SBI,SBN3-9	1.5	387	678	412	703	177	141	33.9	34.9
SBI,SBN3-10	1.5	405	696	430	721	177	141	34.3	35.2
SBI,SBN3-11	1.5	423	714	448	739	177	141	34.7	35.6
SBI,SBN3-12	2.2	441	732	466	757	177	141	37.9	38.8
SBI,SBN3-13	2.2	459	750	484	775	177	141	38.3	39.2
SBI,SBN3-15	2.2	495	786	520	811	177	141	38.9	39.9
SBI,SBN3-17	2.2	531	822	556	847	177	141	39.7	40.6
SBI,SBN3-19	3	572	888	597	913	197	147	47.6	48.5
SBI,SBN3-21	3	608	924	633	949	197	147	48.3	49.3
SBI,SBN3-23	3	644	960	669	985	197	147	49.1	50.0
SBI,SBN3-25	4	680	1006	705	1031	220	161	53.2	54.1

性能曲線-SB,SBI,SBN 5

Vertical Multistage Centrifugal In-line Pumps



STAIRS PUMPS

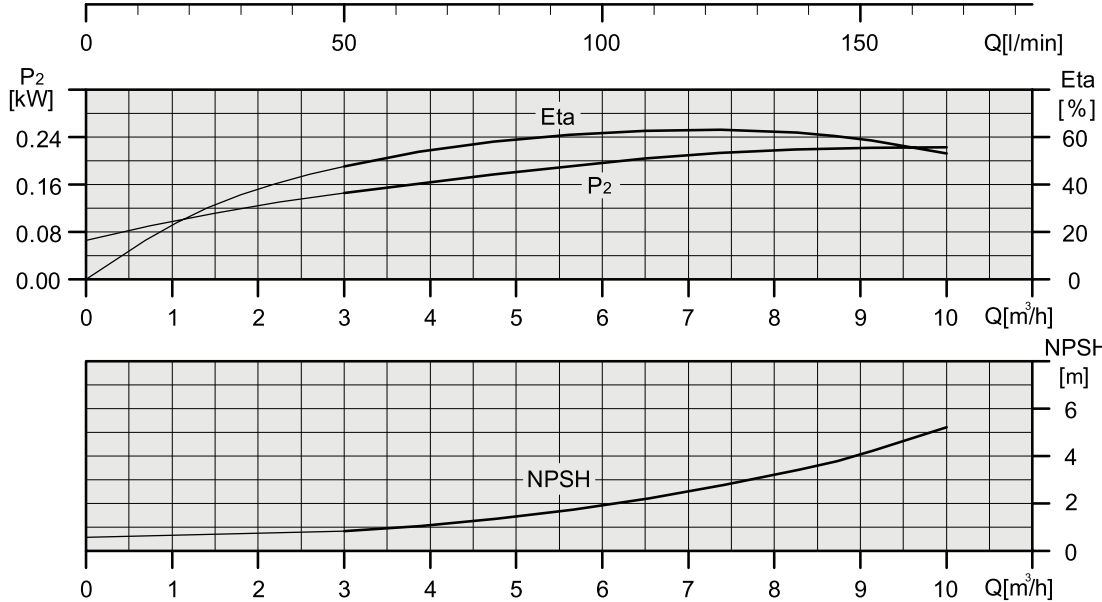
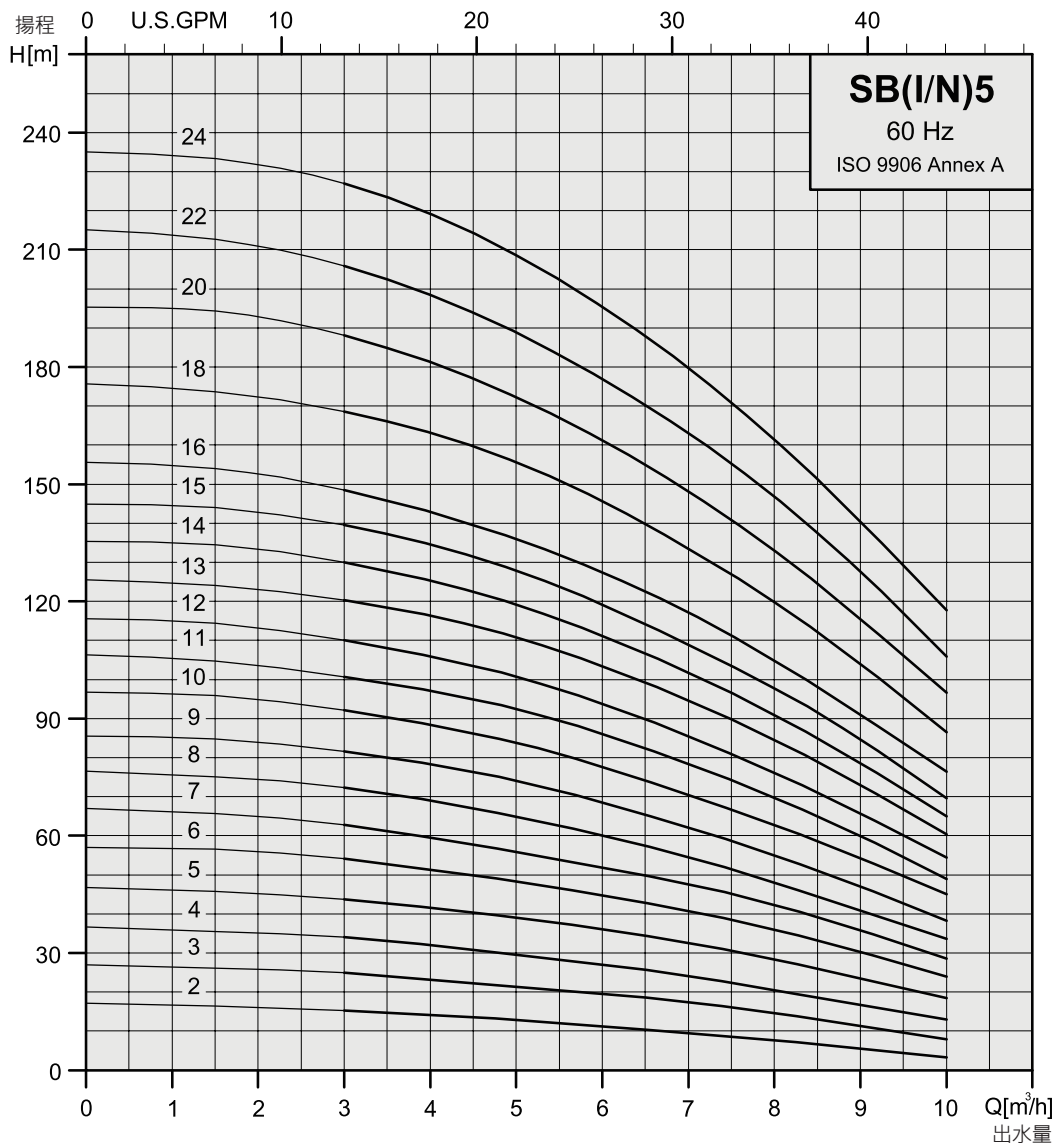

外型尺寸-SB 5

Vertical Multistage Centrifugal In-line Pumps



STAIRS PUMPS

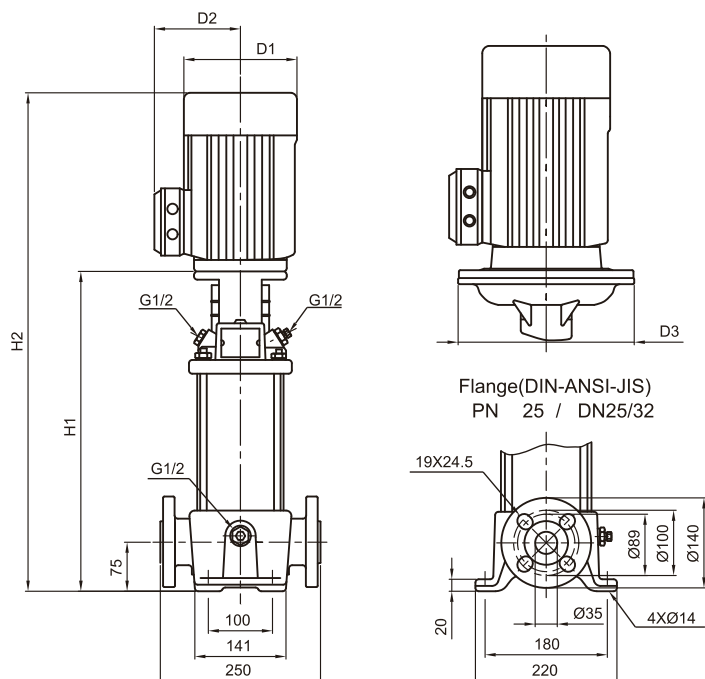

型號	馬達 P ₂ 功率	SB 5					重量 [kg] DIN flange
		尺寸[mm]					
		DIN flange		D1	D2	D3	
		H1	H2				
SB5-2	0.55	279	474	141	115	—	23.8
SB5-3	1.1	312	547	141	115	—	27.5
SB5-4	1.1	339	574	141	115	—	28.0
SB5-5	1.5	382	673	177	141	—	37.2
SB5-6	2.2	409	700	177	141	—	40.6
SB5-7	2.2	436	727	177	141	—	41.1
SB5-8	2.2	463	754	177	141	—	41.6
SB5-9	2.2	490	781	177	141	—	42.1
SB5-10	3	521	837	197	147	—	50.2
SB5-11	3	548	864	197	147	—	50.7
SB5-12	3	575	891	197	147	—	51.2
SB5-13	4	602	928	220	161	—	55.1
SB5-14	4	629	955	220	161	—	55.7
SB5-15	4	656	982	220	161	—	56.1
SB5-16	4	683	1009	220	161	—	56.7
SB5-18	5.5	767	1129	235	197	300	77.9
SB5-20	5.5	821	1183	235	197	300	79.1
SB5-22	5.5	875	1237	235	197	300	80.0
SB5-24	7.5	929	1327	235	197	300	89.6

外型尺寸-SBI,SBN 5

Vertical Multistage Centrifugal In-line Pumps



STAIRS PUMPS

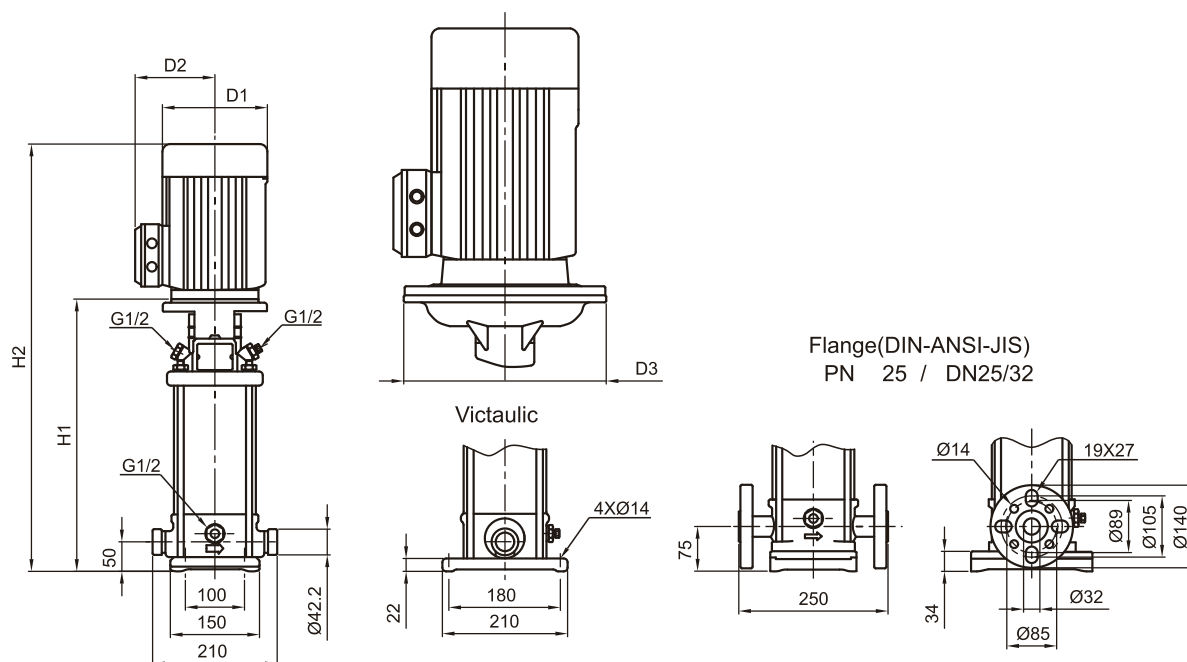

型號	馬達 P ₂ 功率	SBI , SBN 5								
		尺寸[mm]							重量[kg]	
		Victaulic		DIN flange		D1	D2	D3	Victaulic	DIN flange
		H1	H2	H1	H2					
SBI,SBN 5-2	0.55	257	452	282	477	141	115	—	19.7	20.6
SBI,SBN 5-3	1.1	290	525	315	550	141	115	—	23.4	24.4
SBI,SBN 5-4	1.1	317	552	342	577	141	115	—	24.0	24.9
SBI,SBN 5-5	1.5	360	651	385	676	177	141	—	33.3	34.2
SBI,SBN 5-6	2.2	387	678	412	703	177	141	—	36.6	37.6
SBI,SBN 5-7	2.2	414	705	439	730	177	141	—	37.1	38.1
SBI,SBN 5-8	2.2	441	732	466	757	177	141	—	37.7	38.6
SBI,SBN 5-9	2.2	468	759	493	784	177	141	—	38.2	39.2
SBI,SBN 5-10	3	500	816	525	841	197	147	—	46.0	46.9
SBI,SBN 5-11	3	527	843	552	868	197	147	—	46.5	47.4
SBI,SBN 5-12	3	554	870	579	895	197	147	—	47.0	48.0
SBI,SBN 5-13	4	581	907	606	932	220	161	—	51.0	51.9
SBI,SBN 5-14	4	608	934	633	959	220	161	—	51.5	52.5
SBI,SBN 5-15	4	635	961	660	986	220	161	—	52.1	53.0
SBI,SBN 5-16	4	662	988	687	1013	220	161	—	52.6	53.6
SBI,SBN 5-18	5.5	745	1107	770	1132	235	197	300	73.8	74.8
SBI,SBN 5-20	5.5	799	1161	824	1186	235	197	300	75.1	76.0
SBI,SBN 5-22	5.5	853	1215	878	1240	235	197	300	75.9	76.9
SBI,SBN 5-24	7.5	907	1305	932	1330	235	197	300	85.6	86.5

性能曲線-SB,SBI,SBN 10

Vertical Multistage Centrifugal In-line Pumps



STAIRS PUMPS

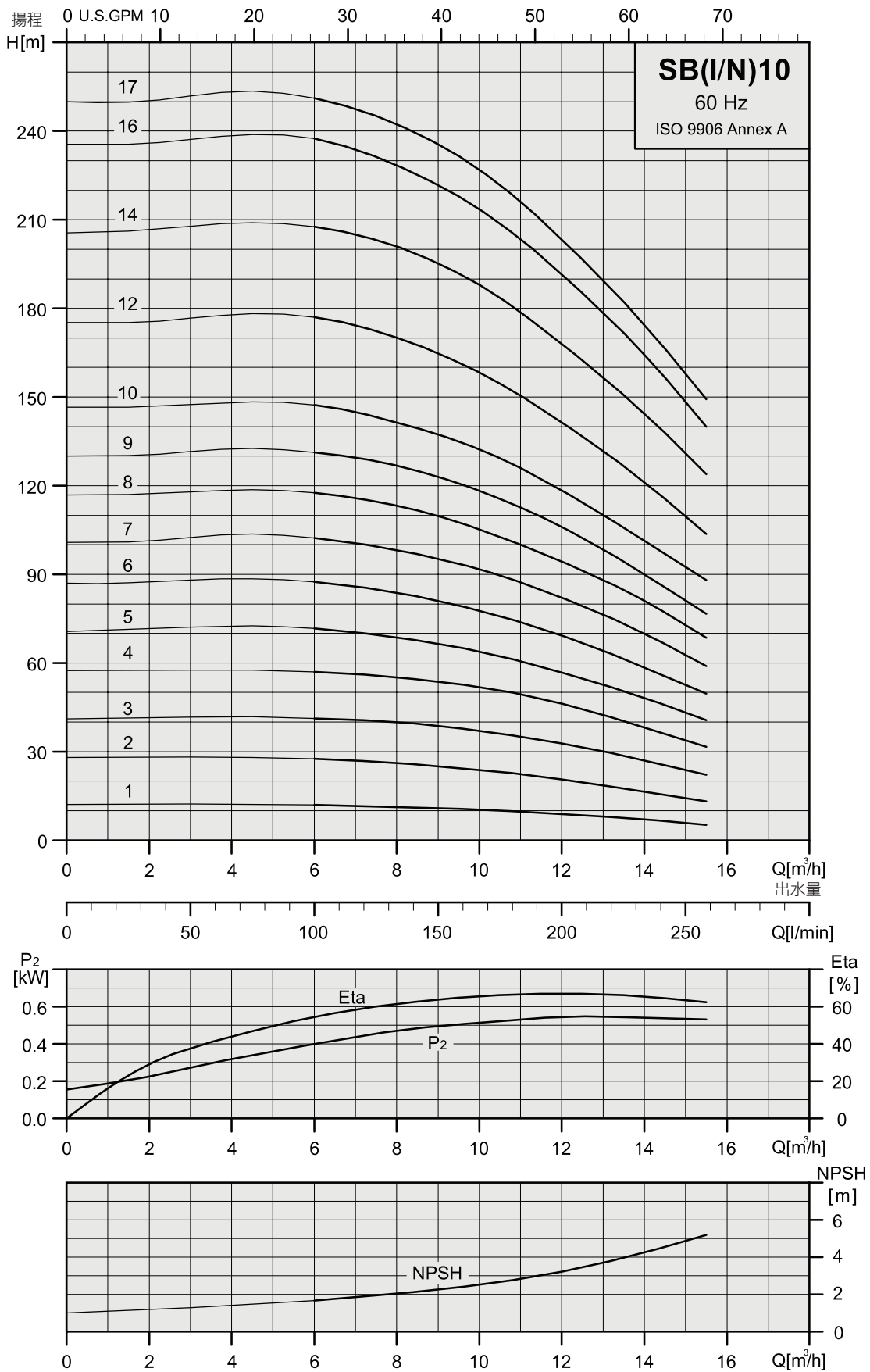

外型尺寸-SB 10

Vertical Multistage Centrifugal In-line Pumps



STAIRS PUMPS

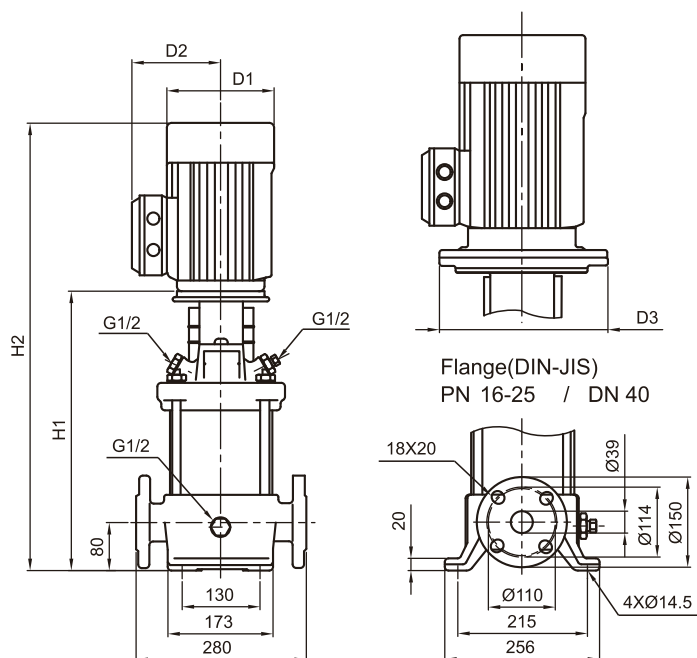

型號	馬達 P ₂ 功率	SB 10					重量 [kg] DIN flange
		尺寸[mm]					
		DIN flange		D1	D2	D3	
		H1	H2				
SB 10-1	0.75	347	582	141	115	—	38.0
SB 10-2	1.5	363	654	177	141	—	48.0
SB 10-3	2.2	393	684	177	141	—	51.9
SB 10-4	3	428	744	197	147	—	60.7
SB 10-5	3	458	774	197	147	—	61.7
SB 10-6	4	488	814	220	161	—	66.2
SB 10-7	5.5	550	912	235	197	300	93.4
SB 10-8	5.5	580	942	235	197	300	94.5
SB 10-9	5.5	610	972	235	197	300	95.5
SB 10-10	7.5	640	1038	235	197	300	105.2
SB 10-12	7.5	700	1098	235	197	300	107.2
SB 10-14	11	837	1342	318	245	350	146.0
SB 10-16	11	897	1402	318	245	350	148.1
SB 10-17	11	927	1432	318	245	350	149.2

外型尺寸-SBI,SBN 10

Vertical Multistage Centrifugal In-line Pumps



STAIRS PUMPS

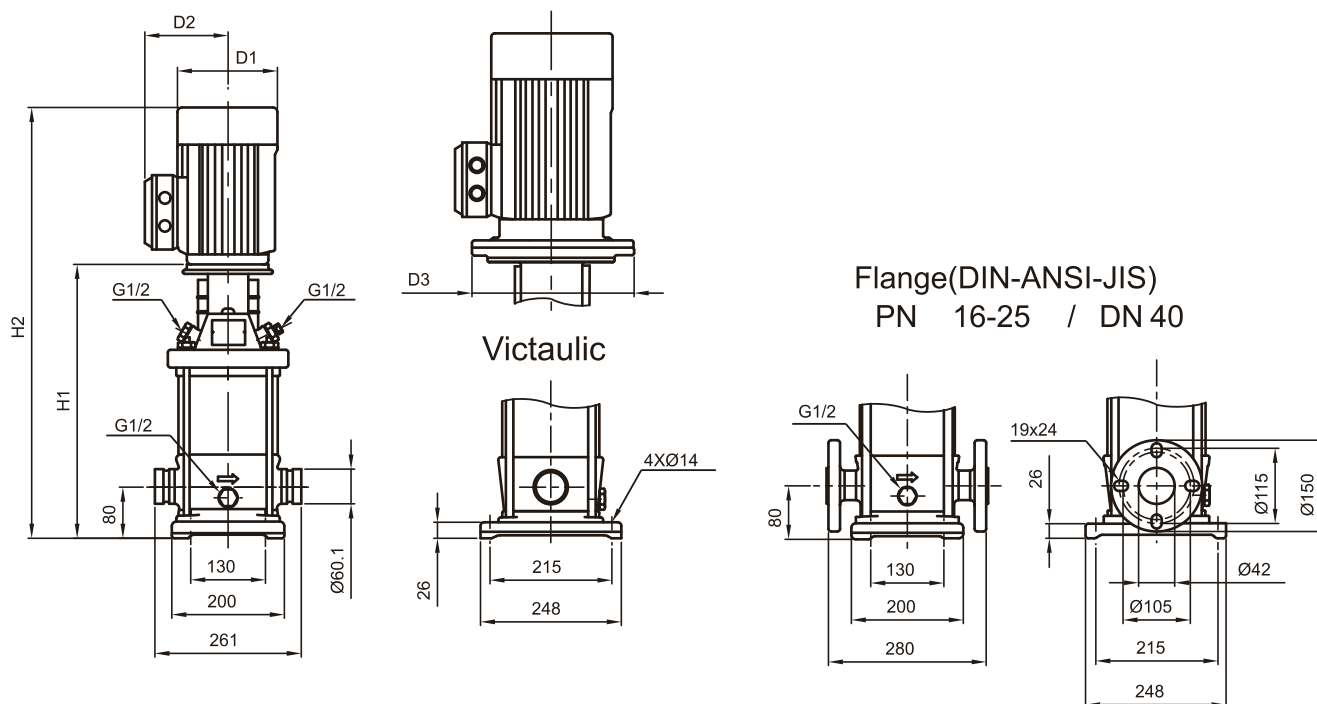

型號	馬達 P ₂ 功率	SBI , SBN 10								
		尺寸[mm]						重量[kg]		
		Victaulic		DIN flange		D1	D2	D3	Victaulic	DIN flange
H1	H2	H1	H2							
SBI,SBN10-1	0.75	357	592	357	592	141	115	—	34.1	34.0
SBI,SBN10-2	1.5	373	664	373	664	177	141	—	44.1	44.0
SBI,SBN10-3	2.2	403	694	403	694	177	141	—	47.9	47.8
SBI,SBN10-4	3	438	754	438	754	197	147	—	55.9	55.8
SBI,SBN10-5	3	468	784	468	784	197	147	—	57.0	56.8
SBI,SBN10-6	4	498	824	498	824	220	161	—	61.4	61.3
SBI,SBN10-7	5.5	560	922	560	922	235	197	300	89.8	89.7
SBI,SBN10-8	5.5	590	952	590	952	235	197	300	90.9	90.7
SBI,SBN10-9	5.5	620	982	620	982	235	197	300	91.9	91.7
SBI,SBN10-10	7.5	650	1048	650	1048	235	197	300	101.5	101.4
SBI,SBN10-12	7.5	710	1108	710	1108	235	197	300	103.6	103.4
SBI,SBN10-14	11	847	1352	847	1352	318	245	350	142.7	142.5
SBI,SBN10-16	11	907	1412	907	1412	318	245	350	144.7	144.6
SBI,SBN10-17	11	937	1442	937	1442	318	245	350	145.9	145.7

性能曲線-SB,SBI,SBN 15

Vertical Multistage Centrifugal In-line Pumps



STAIRS PUMPS

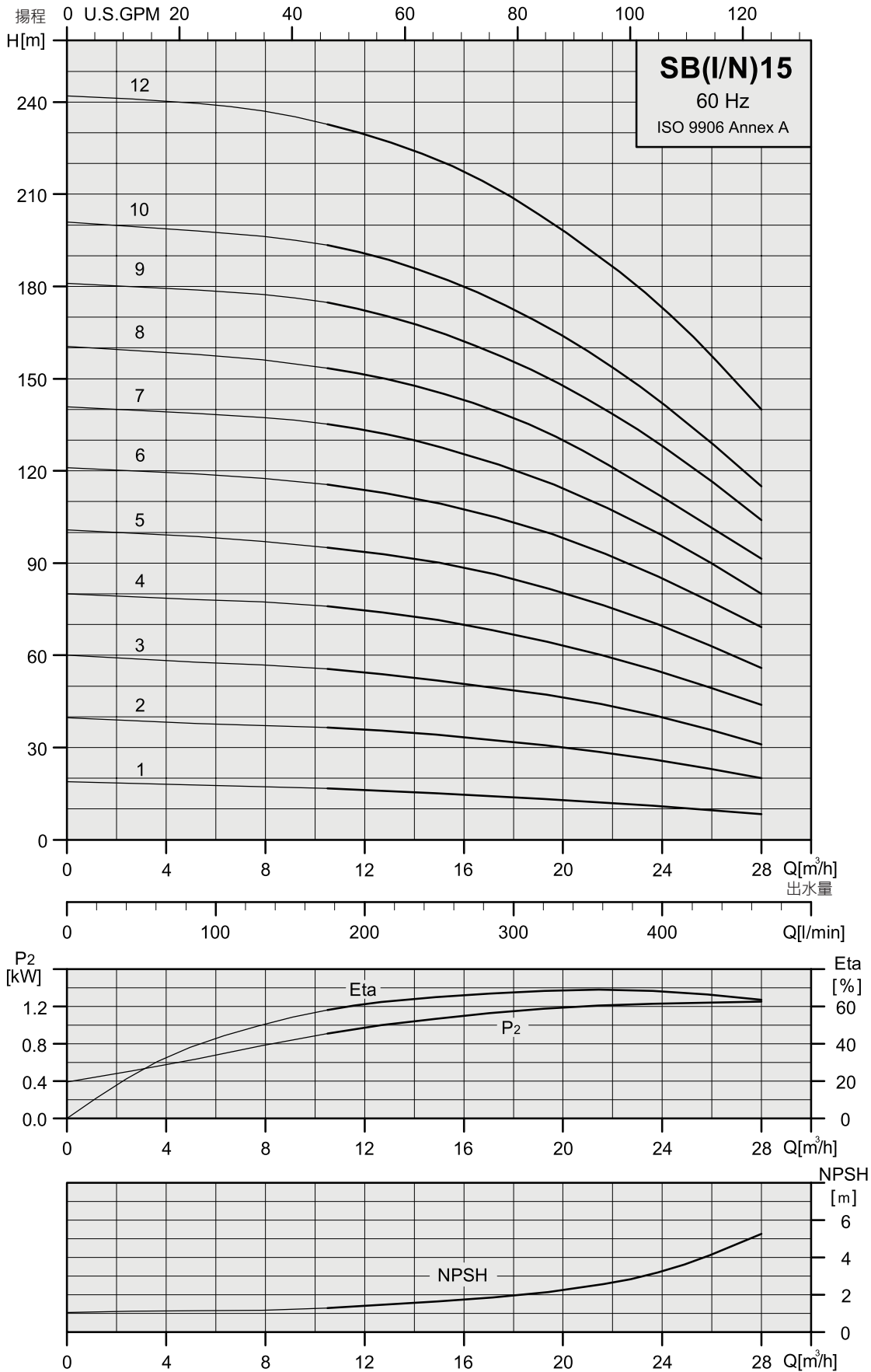

外型尺寸-SB 15

Vertical Multistage Centrifugal In-line Pumps



STAIRS PUMPS

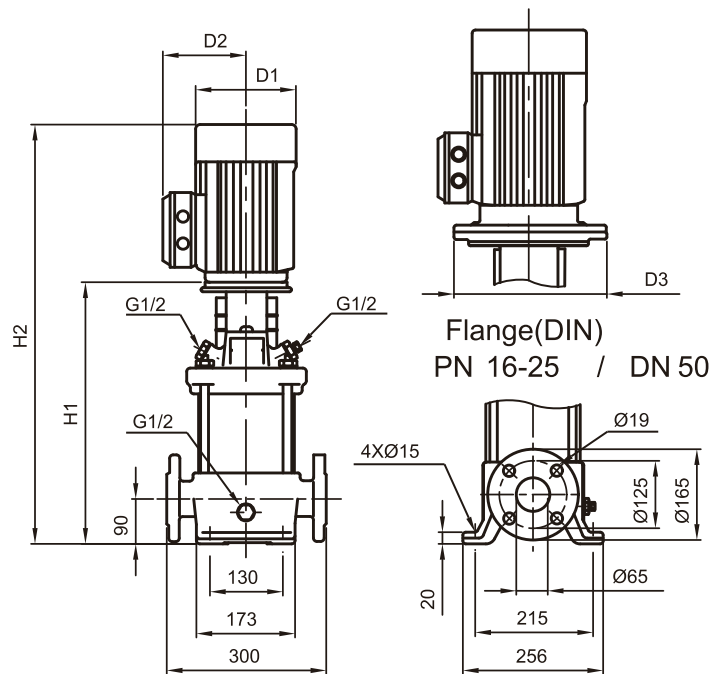

型號	馬達 P ₂ 功率	SB 15					重量 [kg] DIN flange
		尺寸[mm]					
		DIN flange		D1	D2	D3	
		H1	H2				
SB 15-1	1.5	415	706	177	141	—	52.6
SB 15-2	3	420	736	197	147	—	63.5
SB 15-3	4	465	791	220	161	—	68.3
SB 15-4	5.5	542	904	235	197	300	96.0
SB 15-5	7.5	587	985	235	197	300	106.0
SB 15-6	11	709	1214	318	245	350	144.2
SB 15-7	11	754	1259	318	245	350	145.7
SB 15-8	11	799	1304	318	245	350	147.1
SB 15-9	15	844	1354	318	245	350	158.6
SB 15-10	15	889	1399	318	245	350	160.1
SB 15-12	18.5	979	1529	318	245	350	188.0

外型尺寸-SBI,SBN 15

Vertical Multistage Centrifugal In-line Pumps



STAIRS PUMPS

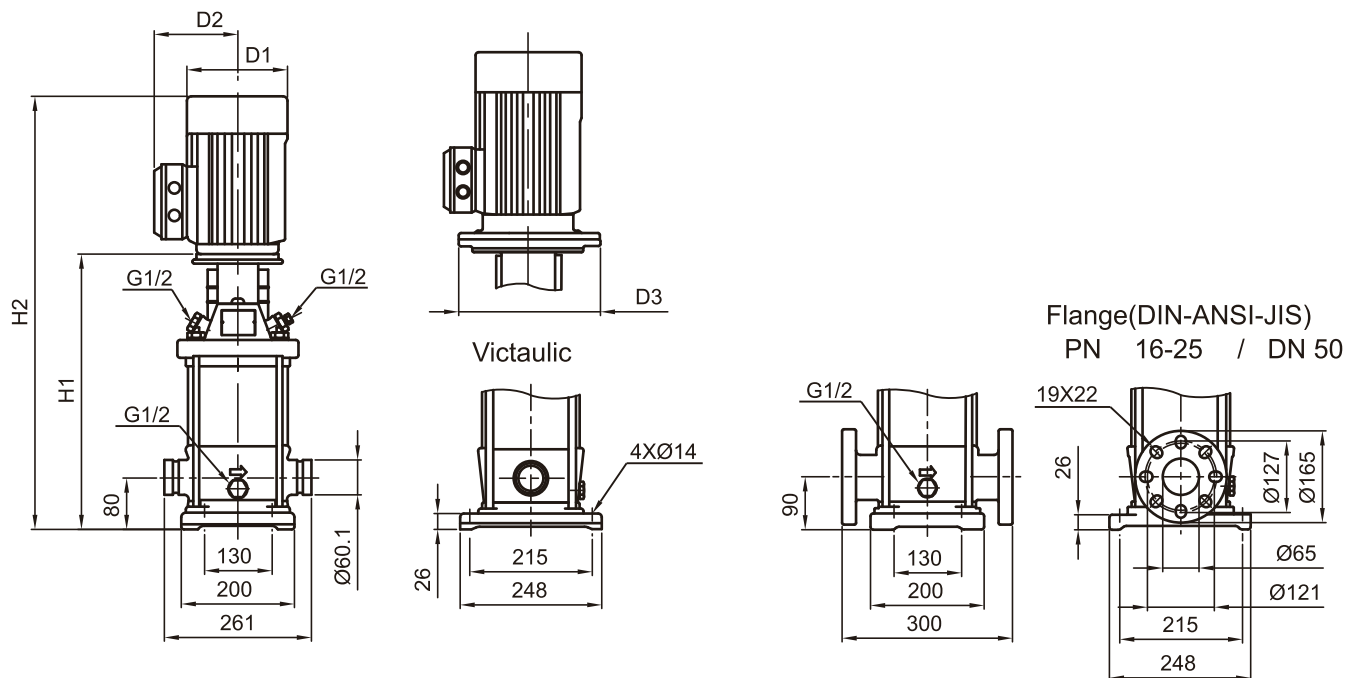

型號	馬達 P ₂ 功率	SBI , SBN 15							重量[kg]			
		尺寸[mm]						D1	D2	D3	Victaulic	DIN flange
		Victaulic		DIN flange		H1	H2					
SBI,SBN15-1	1.5	H1	H2	H1	H2	D1	D2	D3	Victaulic	DIN flange		
SBI,SBN15-2	3	403	694	413	704	177	141	—	44.6	45.3		
SBI,SBN15-3	4	408	724	418	734	197	147	—	54.7	55.3		
SBI,SBN15-4	5.5	453	779	463	789	220	161	—	59.5	60.1		
SBI,SBN15-5	7.5	530	892	540	902	235	197	300	88.3	88.9		
SBI,SBN15-6	11	575	973	585	983	235	197	300	98.3	99.0		
SBI,SBN15-7	11	697	1202	707	1212	318	245	350	136.9	137.5		
SBI,SBN15-8	11	742	1247	752	1257	318	245	350	138.3	138.9		
SBI,SBN15-9	11	787	1292	797	1302	318	245	350	139.7	140.3		
SBI,SBN15-10	15	832	1342	842	1352	318	245	350	151.3	151.9		
SBI,SBN15-11	15	877	1387	887	1397	318	245	350	152.8	153.4		
SBI,SBN15-12	18.5	967	1517	977	1527	318	245	350	180.5	181.2		

性能曲線-SB,SBI,SBN 20

Vertical Multistage Centrifugal In-line Pumps



STAIRS PUMPS

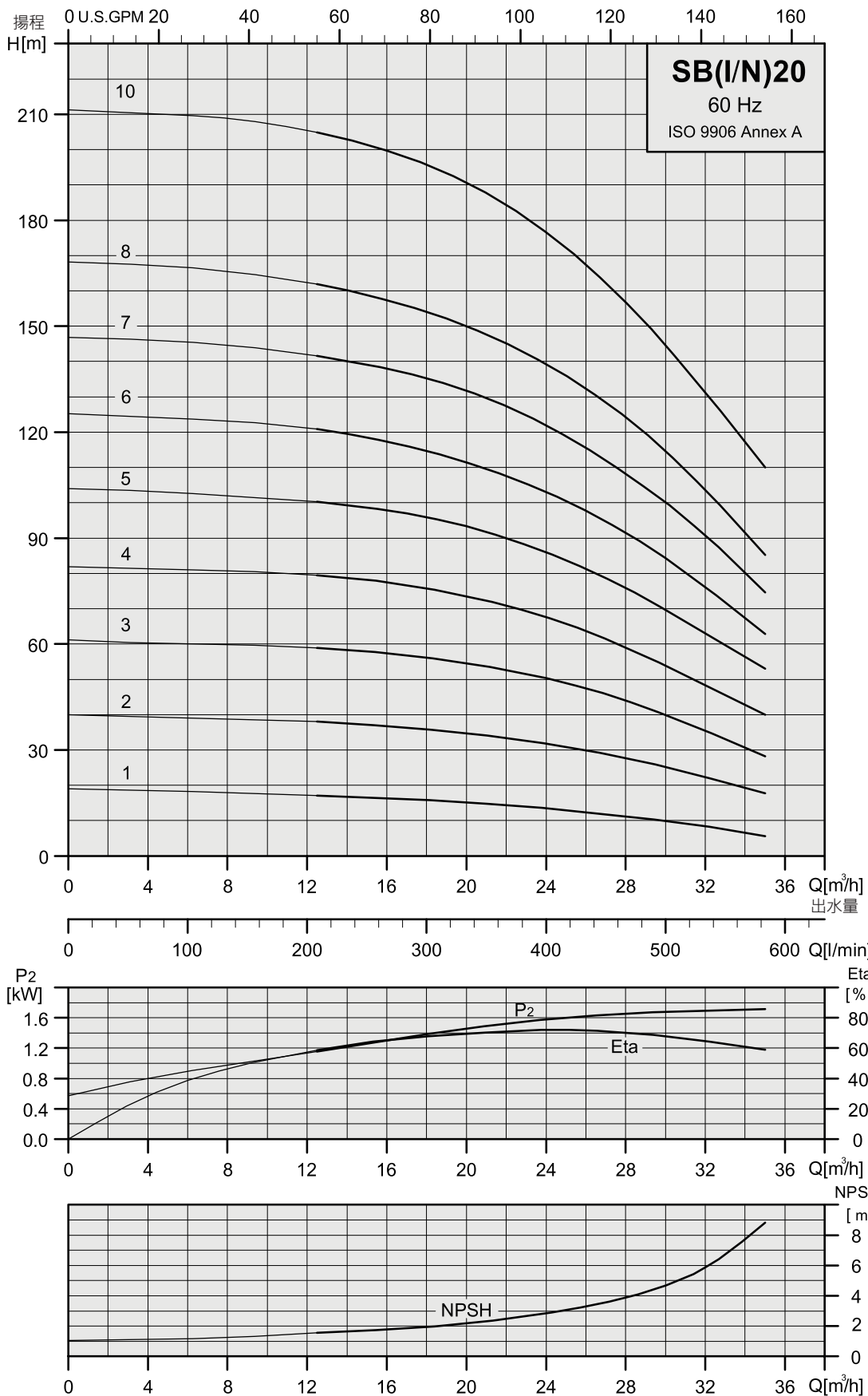

外型尺寸-SB 20

Vertical Multistage Centrifugal In-line Pumps



STAIRS PUMPS

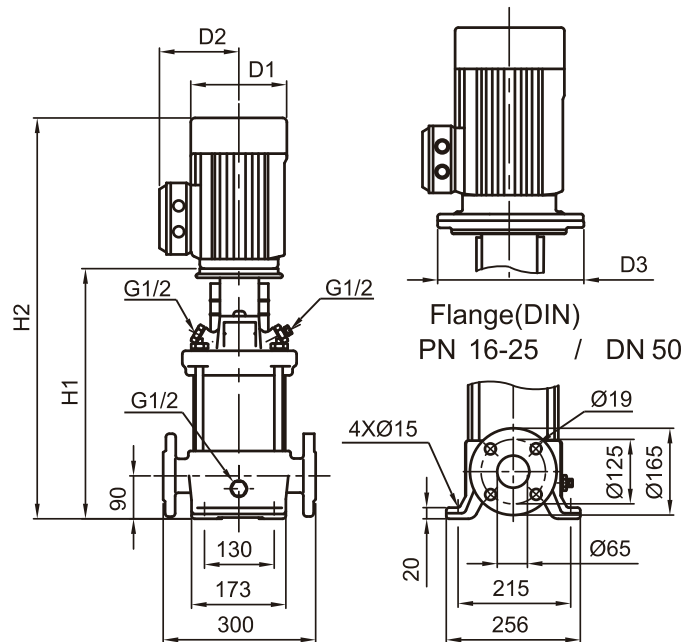

型號	馬達 P ₂ 功率	SB 20					重量 [kg]
		尺寸[mm]					
		DIN flange		D1	D2	D3	DIN flange
H1	H2						
SB 20-1	2.2	415	706	177	141	—	55.4
SB 20-2	4	420	746	220	161	—	66.9
SB 20-3	5.5	497	859	235	197	300	94.6
SB 20-4	7.5	542	940	235	197	300	104.6
SB 20-5	11	664	1169	318	245	350	142.7
SB 20-6	11	709	1214	318	245	350	144.2
SB 20-7	15	754	1264	318	245	350	155.8
SB 20-8	15	799	1309	318	245	350	157.2
SB 20-10	18.5	889	1439	318	245	350	185.0

外型尺寸-SBI,SBN 20

Vertical Multistage Centrifugal In-line Pumps



STAIRS PUMPS

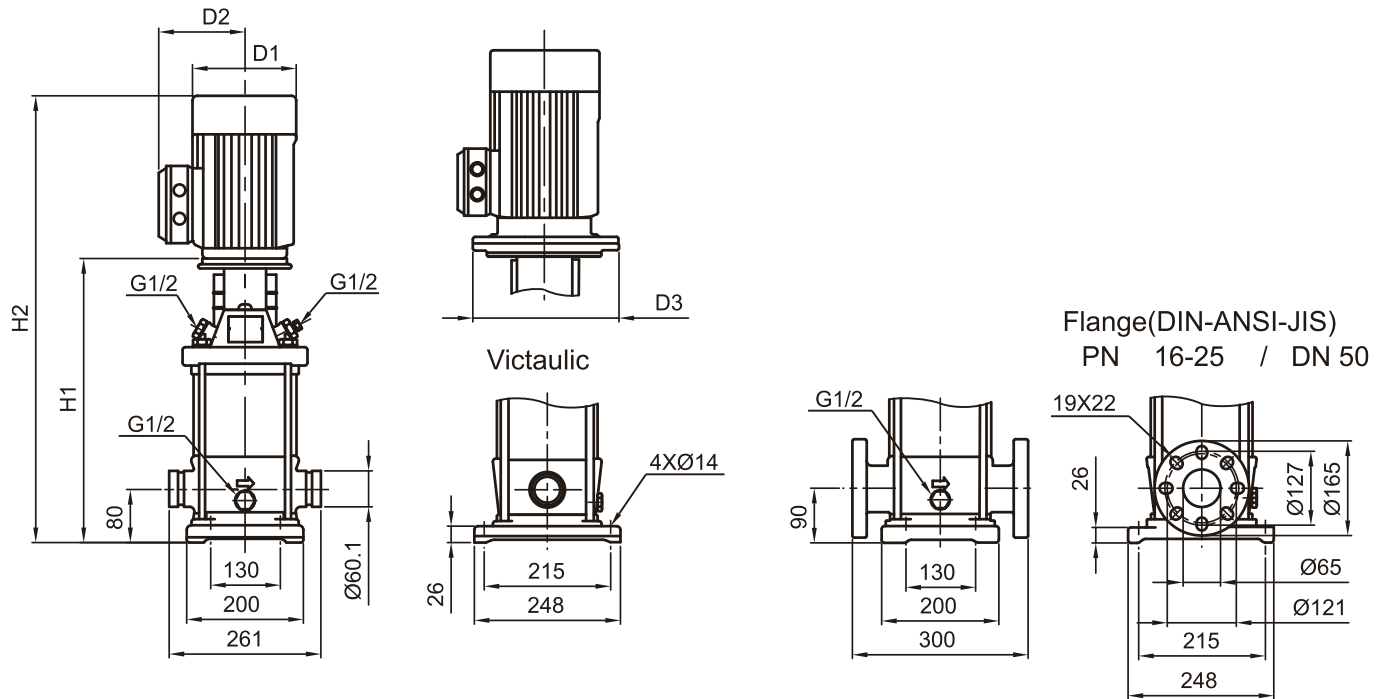

型號	馬達 P ₂ 功率	SBI , SBN 20								
		尺寸[mm]							重量[kg]	
		Victaulic		DIN flange		D1	D2	D3	Victaulic	DIN flange
H1	H2	H1	H2							
SBI,SBN20-1	2.2	405	696	415	706	177	141	—	47.4	48.1
SBI,SBN20-2	4	410	736	420	746	220	161	—	58.1	58.7
SBI,SBN20-3	5.5	487	849	497	859	235	197	300	86.9	87.5
SBI,SBN20-4	7.5	532	930	542	940	235	197	300	96.9	97.5
SBI,SBN20-5	11	654	1159	664	1169	318	245	350	135.4	136.0
SBI,SBN20-6	11	699	1204	709	1214	318	245	350	136.9	137.5
SBI,SBN20-7	15	744	1254	754	1264	318	245	350	148.4	149.0
SBI,SBN20-8	15	789	1299	799	1309	318	245	350	149.8	150.4
SBI,SBN20-10	18.5	879	1429	889	1439	318	245	350	177.7	178.3

性能曲線-SB,SBI,SBN 32

Vertical Multistage Centrifugal In-line Pumps



STAIRS PUMPS

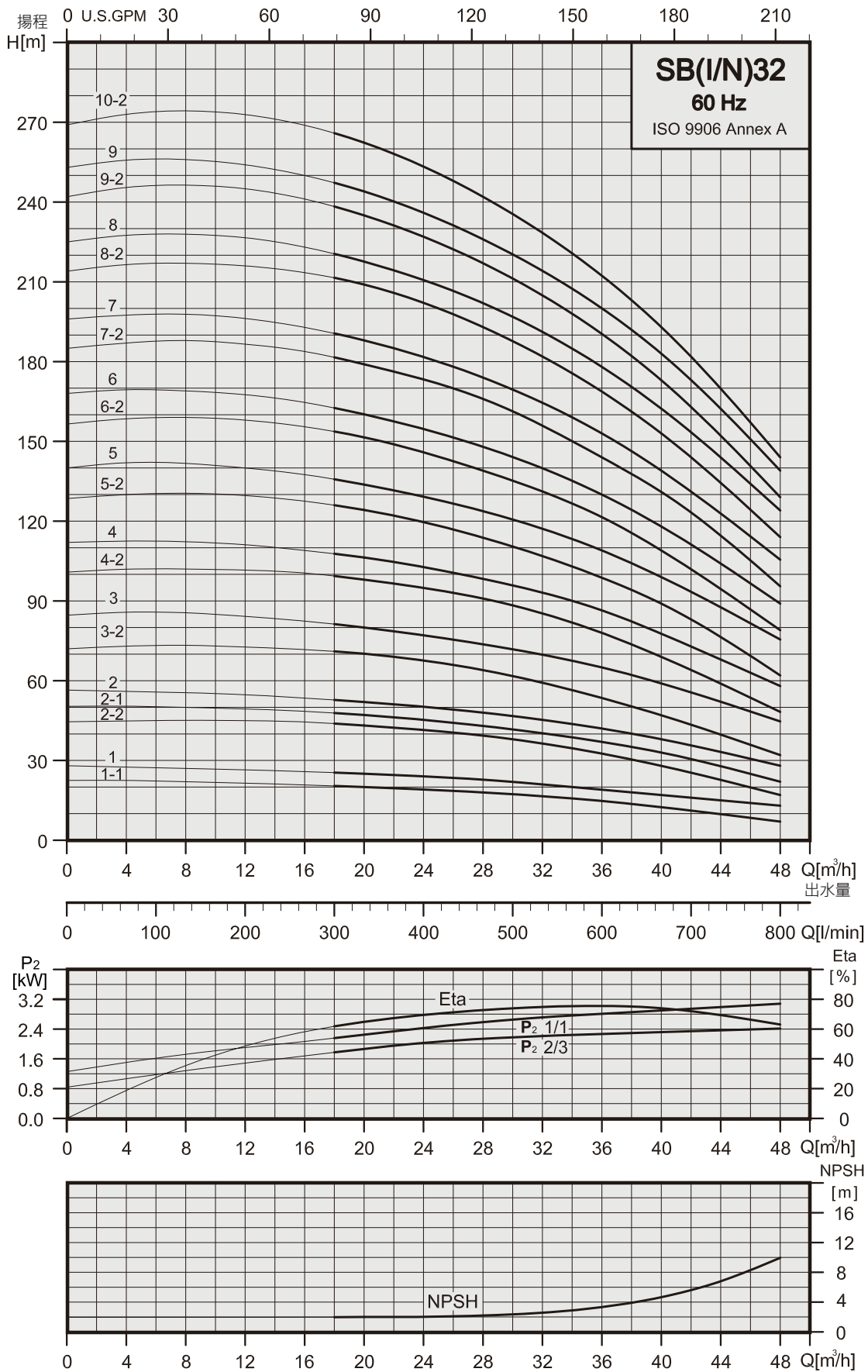

外型尺寸-SB 32

Vertical Multistage Centrifugal In-line Pumps



STAIRS PUMPS

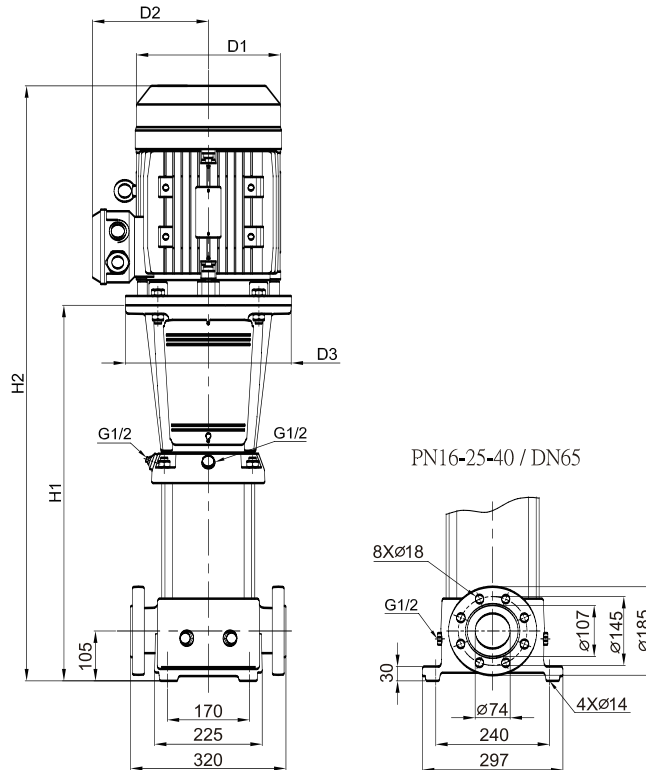

型號	馬達 P ₂ 功率	SB 32					重量 [kg] DIN flange
		DIN flange		尺寸[mm]			
		H1	H2	D1	D2	D3	
SB 32-1-1	2.2	504	795	177	141	280	74.3
SB 32-1	3	504	820	197	147	280	81.1
SB 32-2-2	5.5	574	900	235	197	300	103.6
SB 32-2-1	5.5	574	936	235	197	300	103.7
SB 32-2	7.5	574	972	235	197	300	112.3
SB 32-3-2	11	754	1259	318	245	350	157.0
SB 32-3	11	754	1259	318	245	350	157.1
SB 32-4-2	11	824	1329	318	245	350	160.2
SB 32-4	15	824	1334	318	245	350	170.3
SB 32-5-2	15	894	1404	318	245	350	173.4
SB 32-5	18.5	894	1444	318	245	350	198.3
SB 32-6-2	18.5	964	1514	318	245	350	201.3
SB 32-6	18.5	964	1514	318	245	350	201.3
SB 32-7-2	22	1034	1614	358	265	350	247.2
SB 32-7	22	1034	1614	358	265	350	247.2
SB 32-8-2	30	1104	1764	420	295	400	315.1
SB 32-8	30	1104	1764	420	295	400	315.1
SB 32-9-2	30	1174	1834	420	295	400	317.8
SB 32-9	30	1174	1834	420	295	400	317.8
SB 32-10-2	30	1244	1904	420	295	400	320.5

外型尺寸-SBI,SBN 32

Vertical Multistage Centrifugal In-line Pumps



STAIRS PUMPS

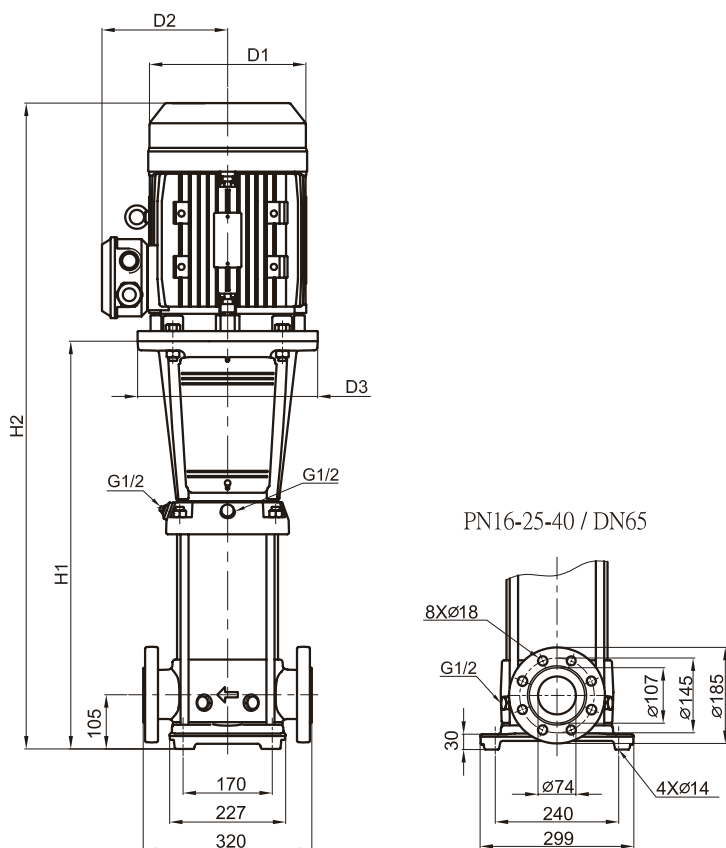

型號	馬達 P ₂ 功率	SBI , SBN 32					重量 [kg] DIN flange
		DIN flange		尺寸[mm]			
		H1	H2	D1	D2	D3	
SBI,SBN 32-1-1	2.2	504	795	177	141	280	69.3
SBI,SBN 32-1	3	504	820	197	147	280	76.0
SBI,SBN 32-2-2	5.5	574	900	235	197	300	98.6
SBI,SBN 32-2-1	5.5	574	936	235	197	300	98.6
SBI,SBN 32-2	7.5	574	972	235	197	300	107.2
SBI,SBN 32-3-2	11	754	1259	318	245	350	152.0
SBI,SBN 32-3	11	754	1259	318	245	350	152.0
SBI,SBN 32-4-2	11	824	1329	318	245	350	155.1
SBI,SBN 32-4	15	824	1334	318	245	350	165.2
SBI,SBN 32-5-2	15	894	1404	318	245	350	168.3
SBI,SBN 32-5	18.5	894	1444	318	245	350	193.3
SBI,SBN 32-6-2	18.5	964	1514	318	245	350	196.3
SBI,SBN 32-6	18.5	964	1514	318	245	350	196.4
SBI,SBN 32-7-2	22	1034	1614	358	265	350	242.2
SBI,SBN 32-7	22	1034	1614	358	265	350	242.3
SBI,SBN 32-8-2	30	1104	1764	420	295	400	310.1
SBI,SBN 32-8	30	1104	1764	420	295	400	310.1
SBI,SBN 32-9-2	30	1174	1834	420	295	400	312.8
SBI,SBN 32-9	30	1174	1834	420	295	400	312.9
SBI,SBN 32-10-2	30	1244	1904	420	295	400	315.5

性能曲線-SB,SBI,SBN 45

Vertical Multistage Centrifugal In-line Pumps



STAIRS PUMPS

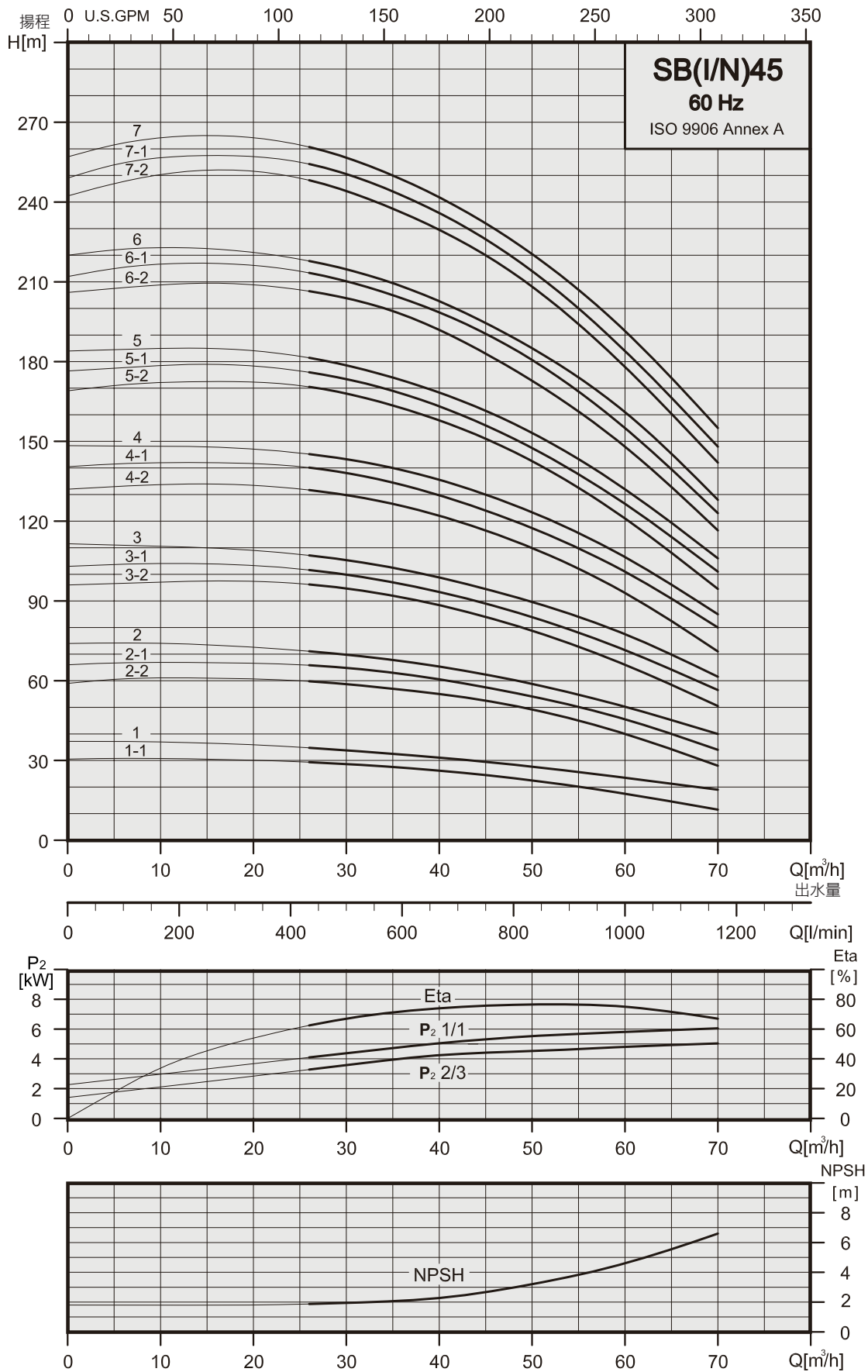

外型尺寸-SB 45

Vertical Multistage Centrifugal In-line Pumps



STAIRS PUMPS

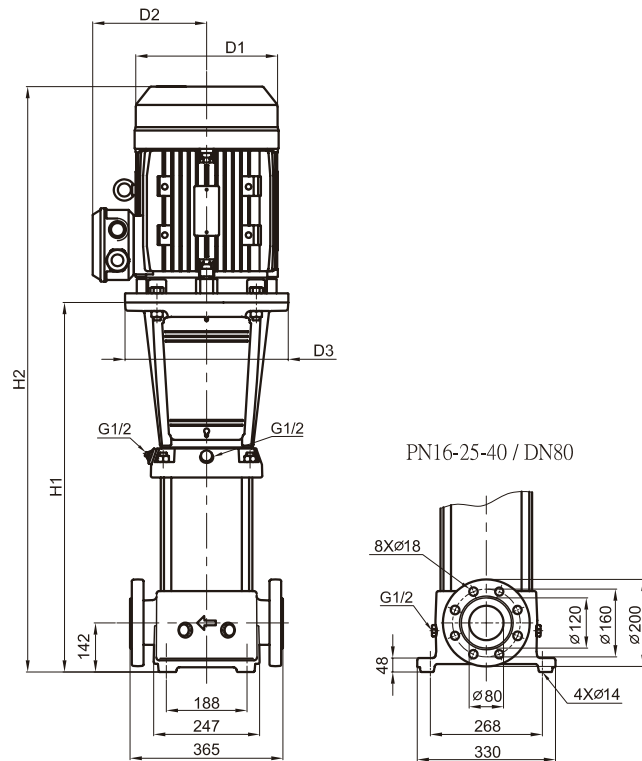

型號	馬達 P ₂ 功率	SB 45					重量 [kg] DIN flange
		DIN flange		尺寸[mm]			
		H1	H2	D1	D2	D3	
SB 45-1-1	5.5	561	923	235	197	300	111.2
SB 45-1	7.5	561	959	235	197	300	119.8
SB 45-2-2	11	751	1256	318	245	350	165.2
SB 45-2-1	11	751	1256	318	245	350	165.2
SB 45-2	15	751	1261	318	245	350	175.3
SB 45-3-2	18.5	831	1381	318	245	350	204.0
SB 45-3-1	18.5	831	1381	318	245	350	204.0
SB 45-3	18.5	831	1381	318	245	350	204.0
SB 45-4-2	22	911	1491	358	265	350	250.5
SB 45-4-1	30	911	1571	420	295	400	315.1
SB 45-4	30	911	1571	420	295	400	315.1
SB 45-5-2	30	991	1651	420	295	400	318.9
SB 45-5-1	30	991	1651	420	295	400	318.9
SB 45-5	30	991	1651	420	295	400	318.9
SB 45-6-2	37	1071	1731	420	295	400	335.7
SB 45-6-1	37	1071	1731	420	295	400	335.7
SB 45-6	37	1071	1731	420	295	400	335.7
SB 45-7-2	45	1151	1841	470	325	450	397.5
SB 45-7-1	45	1151	1841	470	325	450	397.5
SB 45-7	45	1151	1841	470	325	450	397.6

外型尺寸-SBI,SBN 45

Vertical Multistage Centrifugal In-line Pumps



STAIRS PUMPS

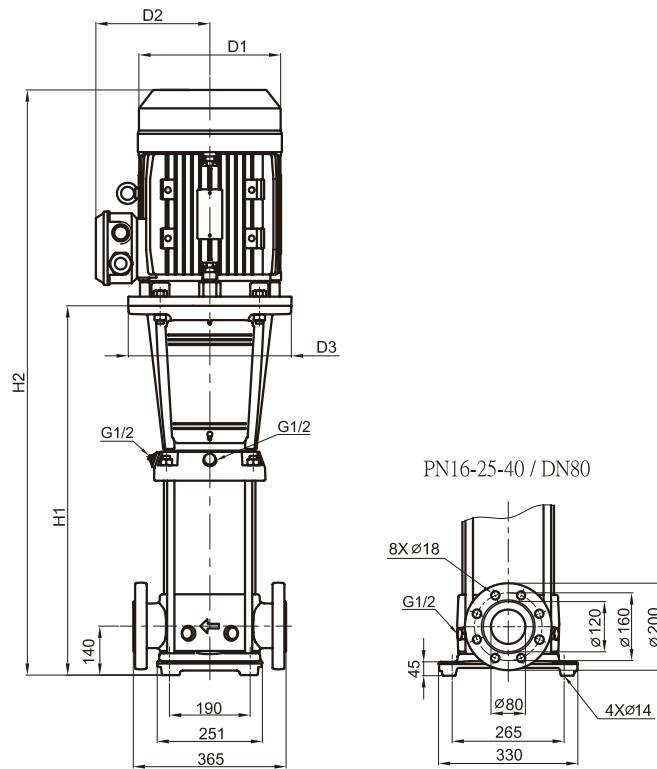

型號	馬達	SBI , SBN 45					重量 [kg]	
		尺寸[mm]						
		P ₂ 功率	DIN flange		D1	D2		D3
			H1	H2				
SBI,SBN45-1-1	5.5	559	921	235	197	300	102.4	
SBI,SBN 45-1	7.5	559	957	235	197	300	111.0	
SBI,SBN 45-2-2	11	749	1254	318	245	350	156.4	
SBI,SBN 45-2-1	11	749	1254	318	245	350	156.4	
SBI,SBN 45-2	15	749	1259	318	245	350	166.5	
SBI,SBN 45-3-2	18.5	829	1379	318	245	350	195.2	
SBI,SBN 45-3-1	18.5	829	1379	318	245	350	195.2	
SBI,SBN 45-3	18.5	829	1379	318	245	350	195.2	
SBI,SBN 45-4-2	22	909	1489	358	265	350	241.7	
SBI,SBN 45-4-1	30	909	1569	420	295	400	306.3	
SBI,SBN 45-4	30	909	1569	420	295	400	306.3	
SBI,SBN 45-5-2	30	989	1649	420	295	400	310.1	
SBI,SBN 45-5-1	30	989	1649	420	295	400	310.1	
SBI,SBN 45-5	30	989	1649	420	295	400	310.1	
SBI,SBN 45-6-2	37	1069	1729	420	295	400	326.9	
SBI,SBN 45-6-1	37	1069	1729	420	295	400	326.9	
SBI,SBN 45-6	37	1069	1729	420	295	400	326.9	
SBI,SBN 45-7-2	45	1149	1839	470	325	450	388.7	
SBI,SBN 45-7-1	45	1149	1839	470	325	450	388.8	
SBI,SBN 45-7	45	1149	1839	470	325	450	388.8	

性能曲線-SB,SBI,SBN 45

Vertical Multistage Centrifugal In-line Pumps



STAIRS PUMPS

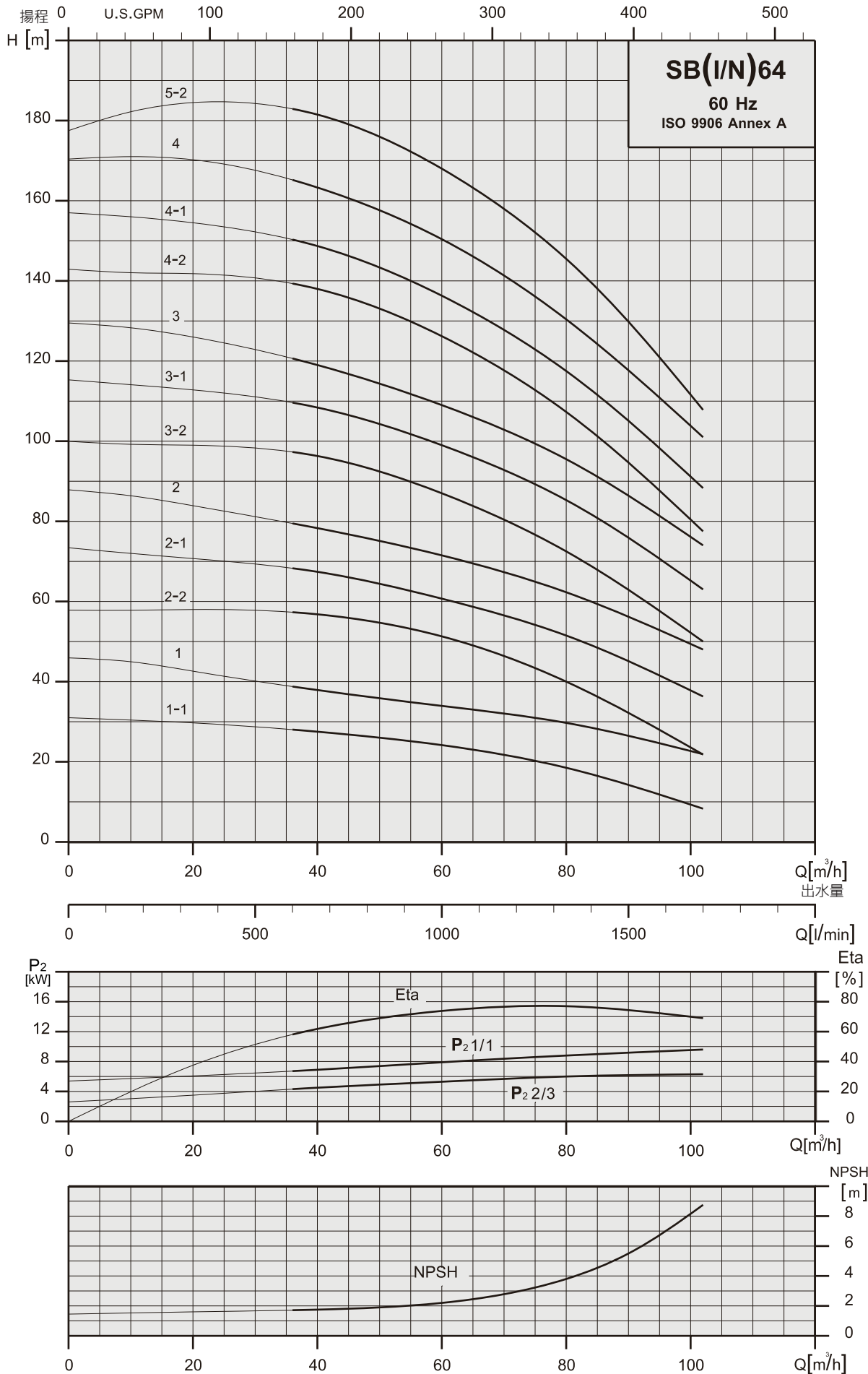

外型尺寸-SB 64

Vertical Multistage Centrifugal In-line Pumps



STAIRS PUMPS

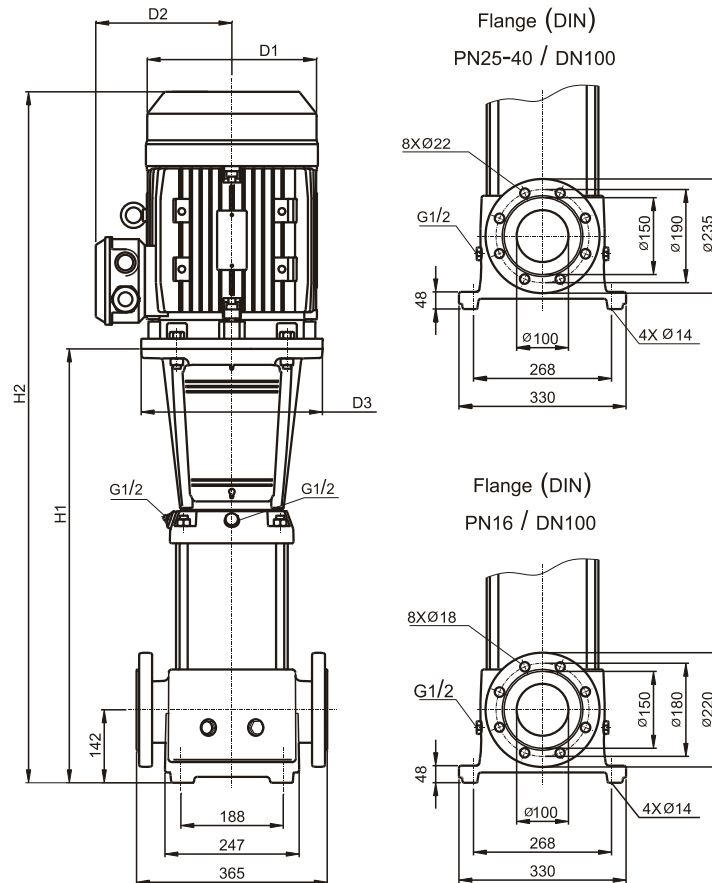

型號	馬達 P ₂ 功率	SB 64					重量 [kg] DIN flange
		DIN flange		尺寸[mm]			
		H1	H2	D1	D2	D3	
SB 64-1-1	7.5	563	961	235	197	300	113.5
SB 64-1	11	673	1178	318	245	350	155.2
SB 64-2-2	15	756	1266	318	245	350	169.4
SB 64-2-1	18.5	756	1306	318	245	350	194.3
SB 64-2	22	756	1336	358	265	350	237.0
SB 64-3-2	22	838	1418	358	265	350	241.6
SB 64-3-1	30	838	1498	420	295	400	306.2
SB 64-3	30	838	1498	420	295	400	306.2
SB 64-4-2	37	921	1581	420	295	400	323.2
SB 64-4-1	37	921	1581	420	295	400	323.2
SB 64-4	45	925	1585	470	325	450	381.4
SB 64-5-2	45	1007	1667	470	325	450	385.4

外型尺寸-SBI,SBN 64

Vertical Multistage Centrifugal In-line Pumps



STAIRS PUMPS

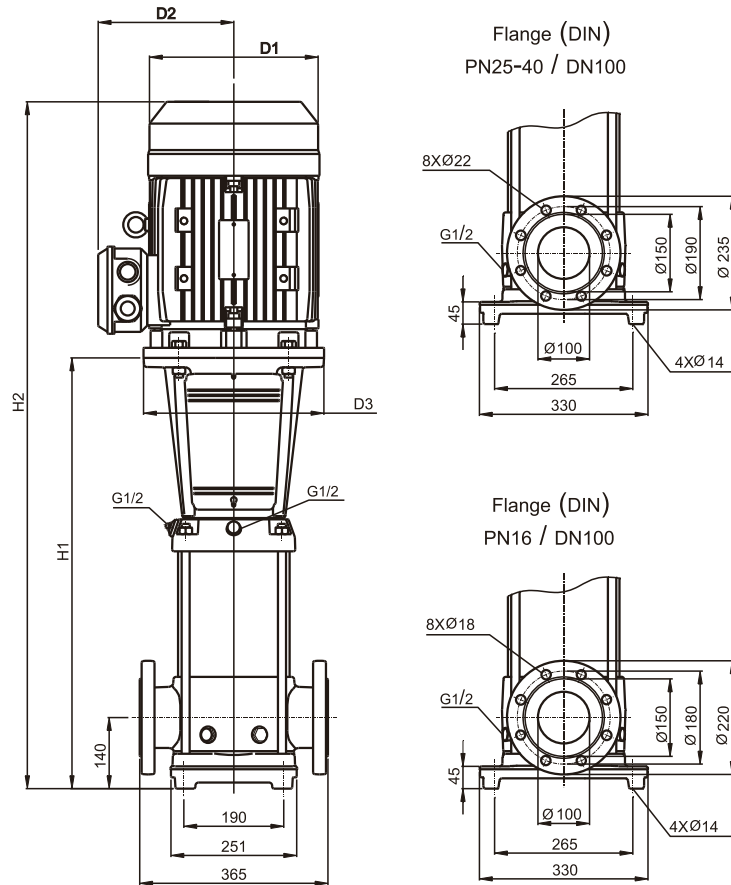

型號	馬達 P ₂ 功率	SBI , SBN 64					重量 [kg] DIN flange
		尺寸[mm]					
		DIN flange		D1	D2	D3	
H1	H2						
SBI,SBN 64-1-1	7.5	563	961	235	197	300	106.5
SBI,SBN 64-1	11	673	1178	318	245	350	148.2
SBI,SBN 64-2-2	15	756	1266	318	245	350	162.4
SBI,SBN 64-2-1	18.5	756	1306	318	245	350	187.3
SBI,SBN 64-2	22	756	1336	358	265	350	230.0
SBI,SBN 64-3-2	22	838	1418	358	265	350	234.1
SBI,SBN 64-3-1	30	838	1498	420	295	400	298.7
SBI,SBN 64-3	30	838	1498	420	295	400	298.7
SBI,SBN 64-4-2	37	921	1581	420	295	400	315.7
SBI,SBN 64-4-1	37	921	1581	420	295	400	315.7
SBI,SBN 64-4	45	925	1585	470	325	450	373.8
SBI,SBN 64-5-2	45	1007	1667	470	325	450	373.7

性能曲線-SB,SBI,SBN 90

Vertical Multistage Centrifugal In-line Pumps



STAIRS PUMPS

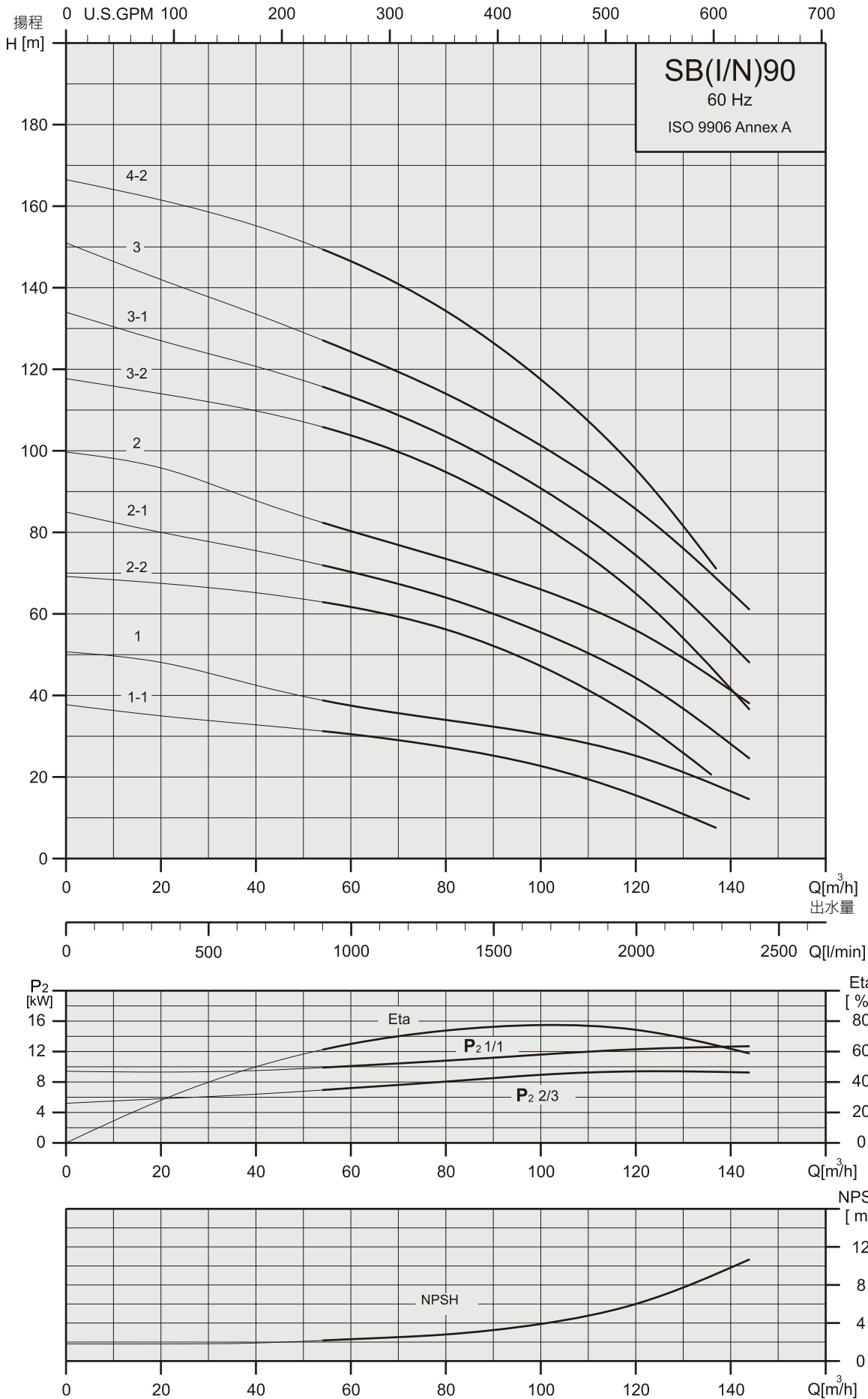

外型尺寸-SB 90

Vertical Multistage Centrifugal In-line Pumps



STAIRS PUMPS

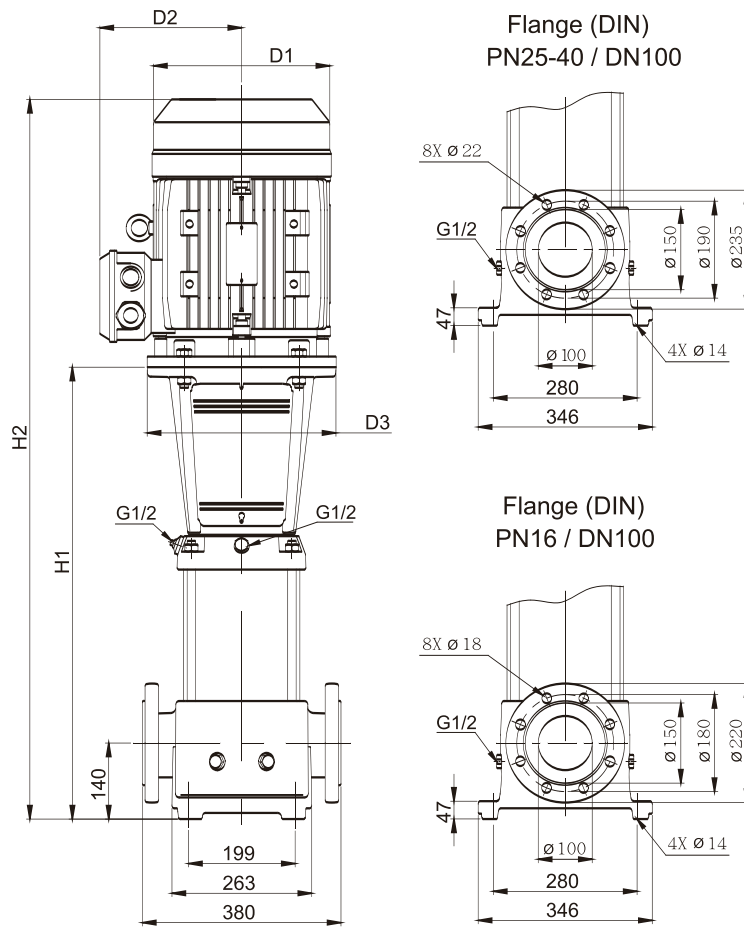

型號	馬達 P ₂ 功率	SB 90					重量 [kg]
		尺寸[mm]			D1	D2	
		DIN flange		H1			H2
SB 90-1-1	11	682	1187	318	245	350	169.1
SB 90-1	15	682	1192	318	245	350	179.1
SB 90-2-2	18.5	774	1324	318	245	350	209.4
SB 90-2-1	22	774	1354	358	265	350	252.2
SB 90-2	30	774	1434	420	295	400	316.8
SB 90-3-2	37	866	1526	420	295	400	335.0
SB 90-3-1	37	866	1526	420	295	400	335.0
SB 90-3	45	866	1556	470	325	450	393.1
SB 90-4-2	45	958	1648	470	325	450	400.3

外型尺寸-SBI,SBN 90

Vertical Multistage Centrifugal In-line Pumps



STAIRS PUMPS

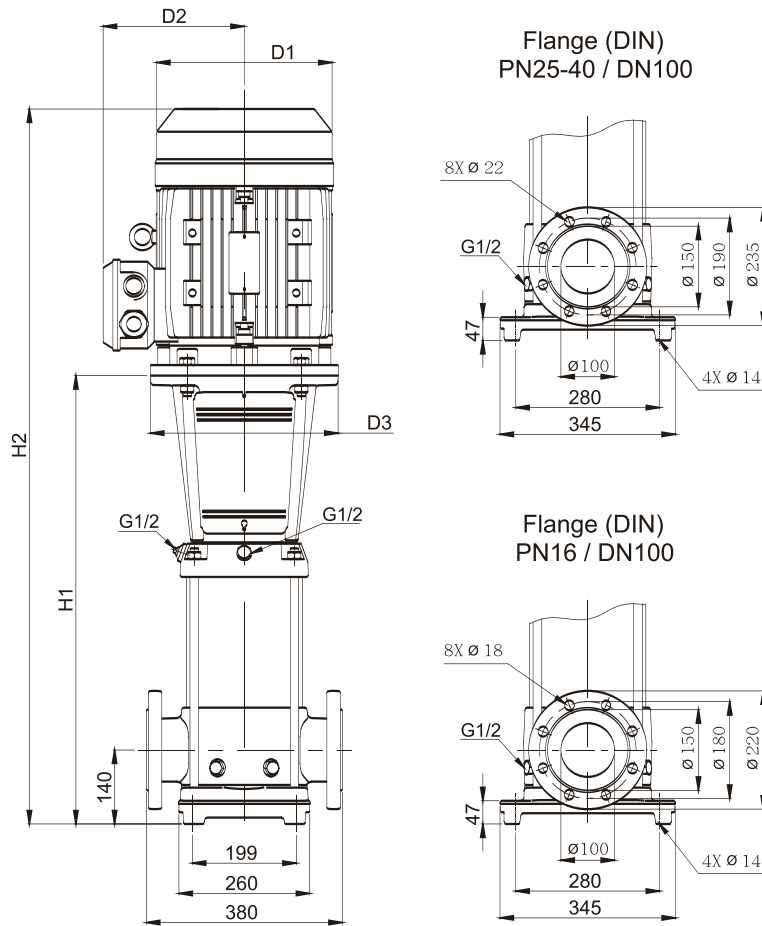

型號	馬達 P ₂ 功率	SBI , SBN 90					重量 [kg] DIN flange
		尺寸[mm]					
		DIN flange		D1	D2	D3	
H1	H2						
SBI,SBN 90-1-1	11	686	1191	318	245	350	159.0
SBI,SBN 90-1	15	686	1196	318	245	350	169.0
SBI,SBN 90-2-2	18.5	778	1328	318	245	350	199.2
SBI,SBN 90-2-1	22	778	1358	358	265	350	242.0
SBI,SBN 90-2	30	778	1438	420	295	400	306.6
SBI,SBN 90-3-2	37	870	1530	420	295	400	324.8
SBI,SBN 90-3-1	37	870	1530	420	295	400	324.8
SBI,SBN 90-3	45	870	1560	470	325	450	382.9
SBI,SBN 90-4-2	45	962	1652	470	325	450	389.9

性能曲線-SB,SBI,SBN 120

Vertical Multistage Centrifugal In-line Pumps



STAIRS PUMPS

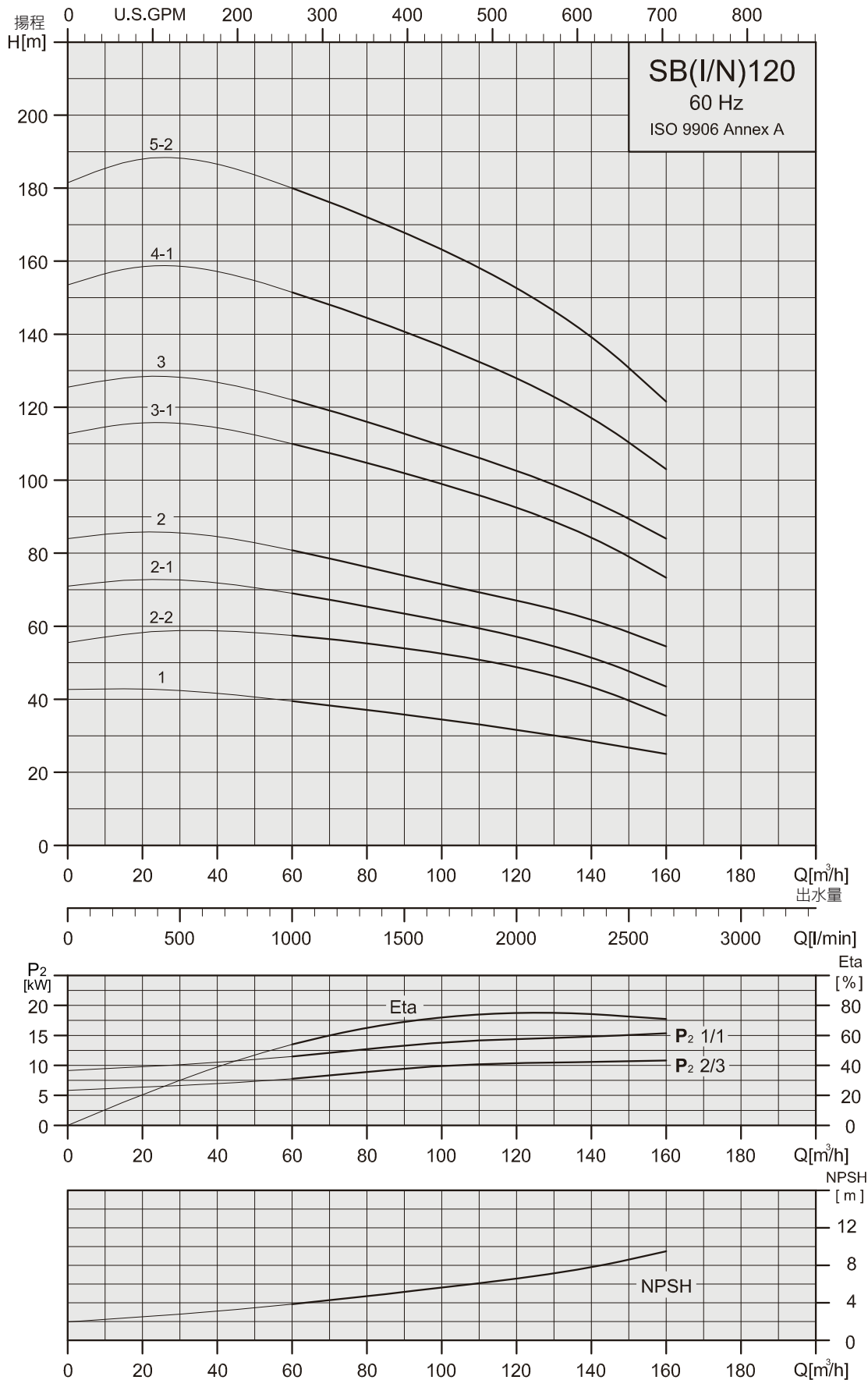

外型尺寸-SB 120

Vertical Multistage Centrifugal In-line Pumps



STAIRS PUMPS

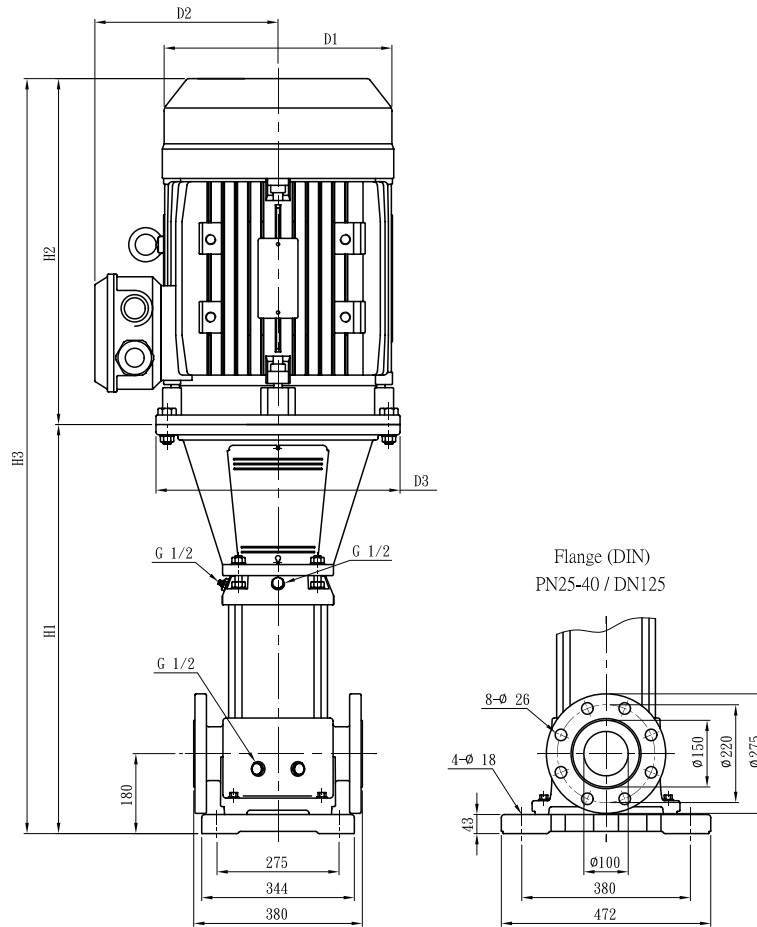

型號	馬達	SB 120							重量 [kg]
		尺寸[mm]							
	P ₂ 功率	DIN flange			D1	D2	D3	DIN flange	
		H1	H2	H3					
SB 120-1	18.5	834	550	1384	318	245	350	235.1	
SB 120-2-2	30	990	660	1650	420	295	400	352.4	
SB 120-2-1	30	990	660	1650	420	295	400	352.5	
SB 120-2	37	990	660	1650	420	295	400	365.5	
SB 120-3-1	45	1149	690	1839	470	325	450	433.5	
SB 120-3	55	1175	770	1945	510	355	550	548.8	
SB 120-4-1	75	1331	845	2176	580	410	550	721.2	
SB 120-5-2	75	1486	845	2331	580	410	550	731.2	

外型尺寸-SBI,SBN 120

Vertical Multistage Centrifugal In-line Pumps



STAIRS PUMPS

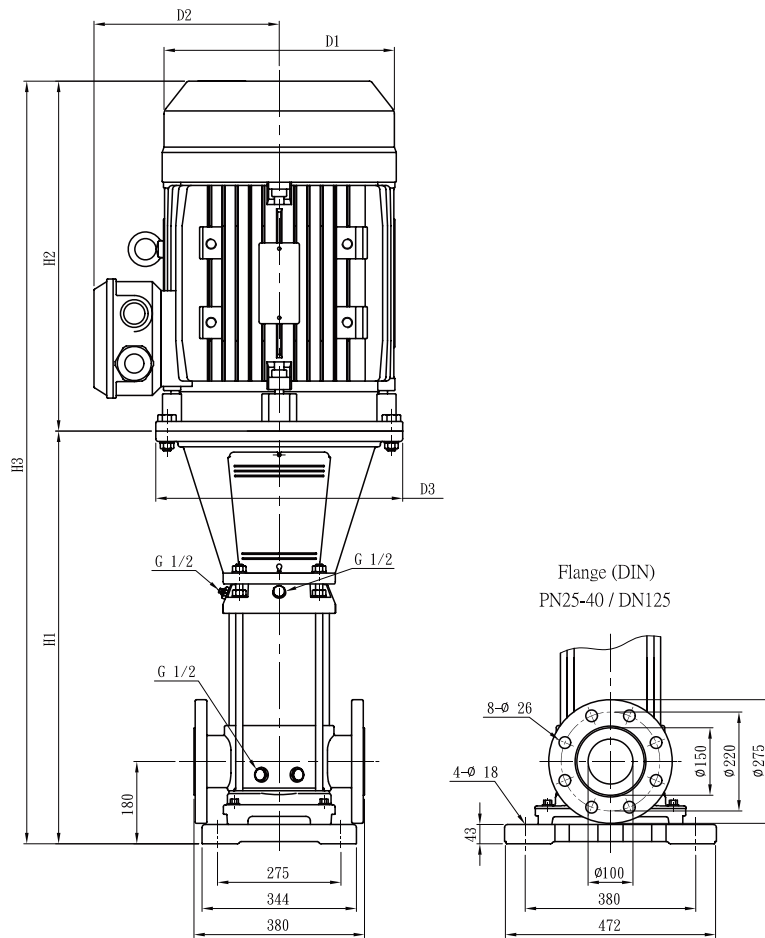

型號	馬達 P ₂ 功率	SBI , SBN 120						重量 [kg]
		尺寸[mm]						
		DIN flange			D1	D2	D3	DIN flange
H1	H2	H3						
SBI,SBN 120-1	18.5	837	550	1387	318	245	350	215.2
SBI,SBN 120-2-2	30	993	660	1653	420	295	400	336.7
SBI,SBN 120-2-1	30	993	660	1653	420	295	400	336.8
SBI,SBN 120-2	37	993	660	1653	420	295	400	349.9
SBI,SBN 120-3-1	45	1152	690	1842	470	325	450	418.0
SBI,SBN 120-3	55	1178	770	1948	510	355	550	533.4
SBI,SBN 120-4-1	75	1334	845	2179	580	410	550	706.0
SBI,SBN 120-5-2	75	1489	845	2334	580	410	550	716.0

性能曲線-SB,SBI,SBN 150

Vertical Multistage Centrifugal In-line Pumps



STAIRS PUMPS

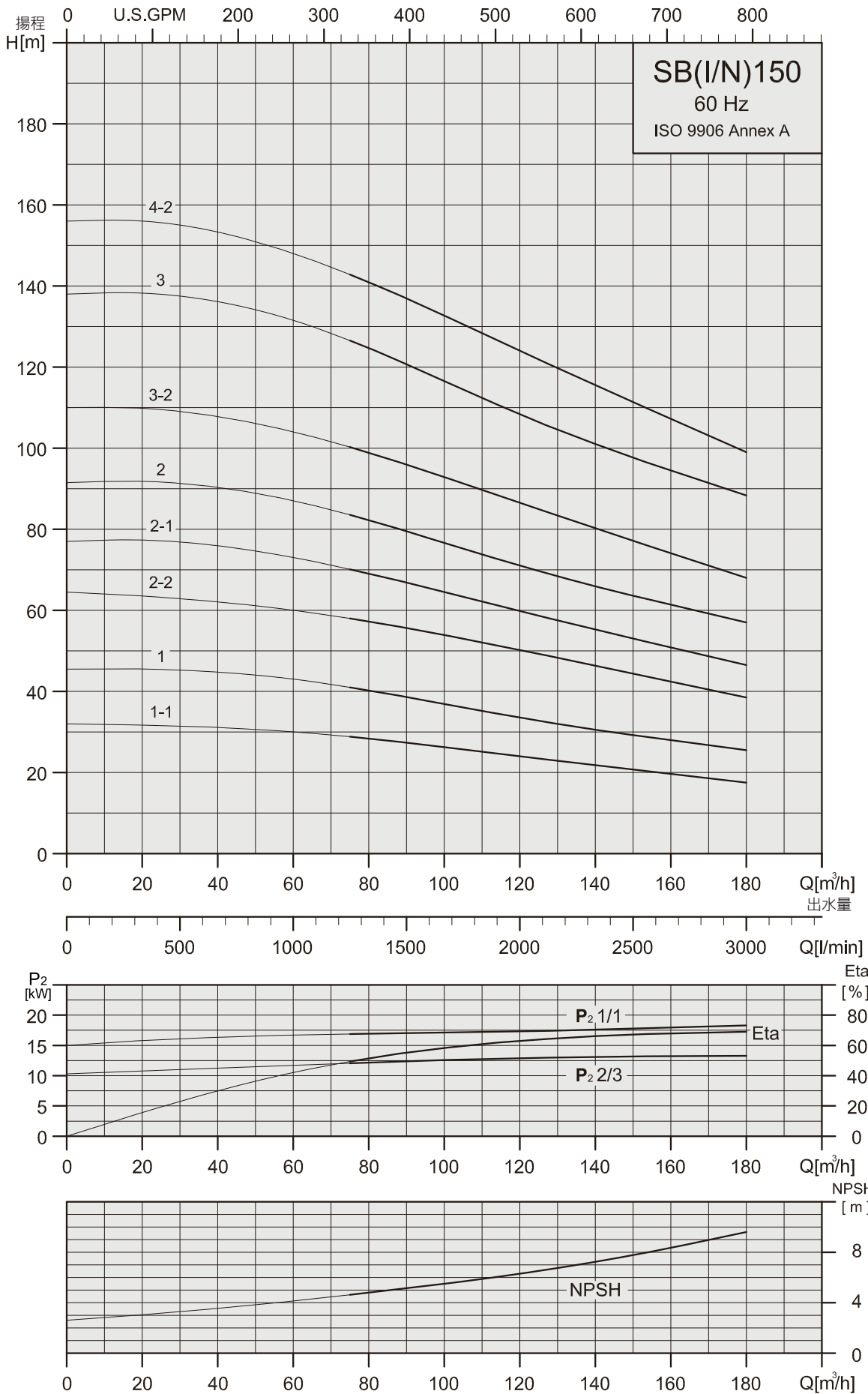

外型尺寸-SB 150

Vertical Multistage Centrifugal In-line Pumps



STAIRS PUMPS

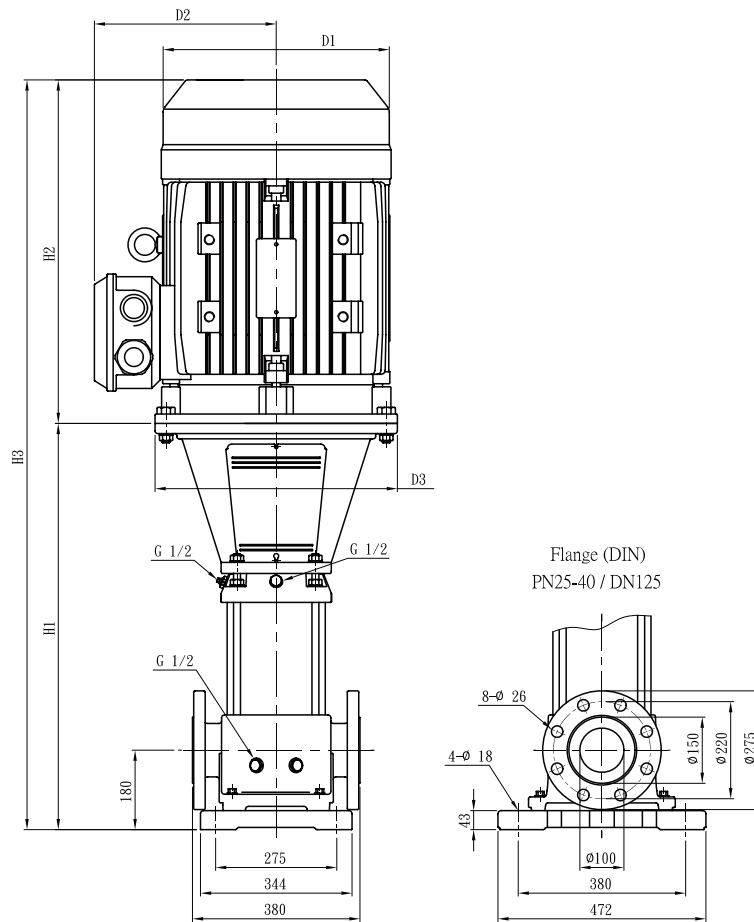

型號	馬達 P ₂ 功率	SB 150						重量 [kg]
		尺寸[mm]						
		DIN flange			D1	D2	D3	DIN flange
H1	H2	H3						
SB 150-1-1	18.5	834	550	1384	318	245	350	235.0
SB 150-1	22	834	580	1414	358	265	350	277.8
SB 150-2-2	30	990	660	1650	420	295	400	352.4
SB 150-2-1	37	990	660	1650	420	295	400	365.4
SB 150-2	45	994	690	1684	470	325	450	423.5
SB 150-3-2	55	1175	770	1945	510	355	550	548.7
SB 150-3	75	1175	845	2020	580	410	550	711.2
SB 150-4-2	75	1331	845	2176	580	410	550	721.2

外型尺寸-SBI,SBN 150

Vertical Multistage Centrifugal In-line Pumps



STAIRS PUMPS

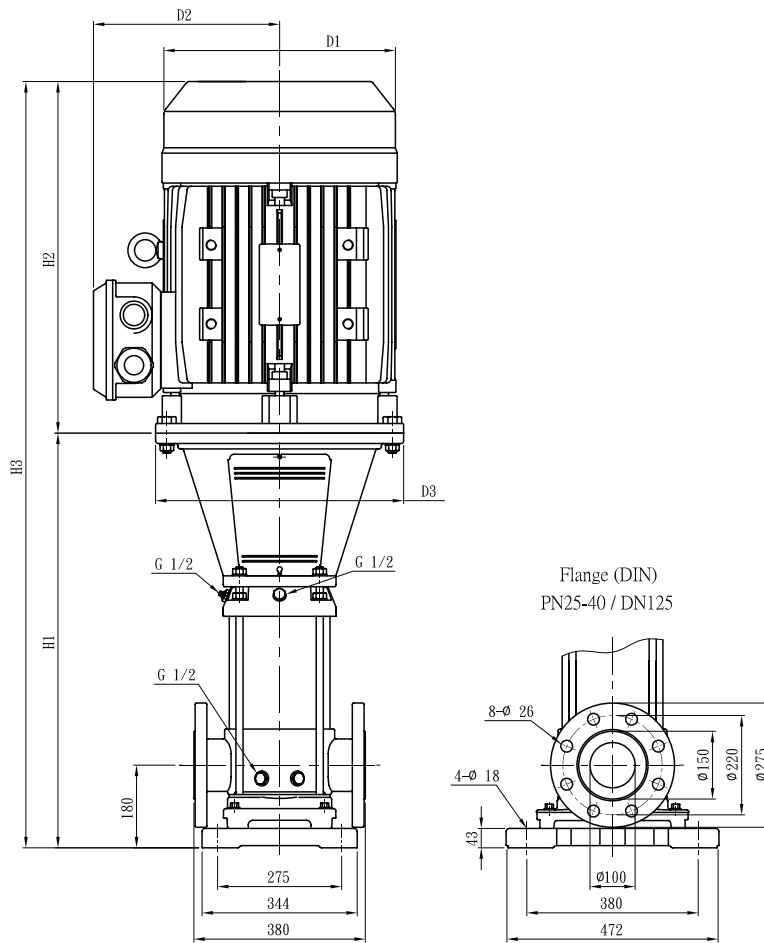

型號	馬達 P ₂ 功率	SBI , SBN 150 尺寸[mm]						重量 [kg] DIN flange
		DIN flange			D1	D2	D3	
		H1	H2	H3				
SBI,SBN 150-1-1	18.5	837	550	1387	318	245	350	218.7
SBI,SBN 150-1	22	837	580	1417	358	265	350	261.7
SBI,SBN 150-2-2	30	993	660	1653	420	295	400	336.1
SBI,SBN 150-2-1	37	993	660	1653	420	295	400	349.1
SBI,SBN 150-2	45	997	690	1687	470	325	450	407.3
SBI,SBN 150-3-2	55	1178	770	1948	510	355	550	532.5
SBI,SBN 150-3	75	1178	845	2023	580	410	550	695.1
SBI,SBN 150-4-2	75	1334	845	2179	580	410	550	704.2



泵浦輸送液體

SB,SBI,SBN 立式離心式泵浦可以處理各式各樣的液體，每種液體都有自己的特性。

SB(I)

非腐蝕性液體

用於液體轉移，循環和增壓冷或熱水

SBN

工業液體

輕酸

列表中所包含的液體並不完整。在處理任何列出的液體時，不同泵材料的應用範圍內的液體被認為是最佳選擇。表格僅作為一般性指導，並且不能代替實際在特定的工作條件下測試泵送的流體和泵浦的材料，

當選擇泵浦時，應充分注意流動介質如密度，凝固點粘度以及防爆要求。還必須考慮泵浦在壓力和溫度上的適用性限制。

● 建議

輸送液體	液體濃度溫度	SB (I)		SBN	
		EPDM	Viton	EPDM	Viton
醋酸酐	25°C			●	
鹼性清潔劑		●			
硫酸鋁	10%, 25°C				●
氨水 (氫氧化鋁)	20%, 40°C	●			
碳酸氫氨	10%, 40°C	●		●	
苯甲酸	10%, 90°C				●
硼酸	不飽和溶液, 60°C				●
丁醇	60°C	●			
醋酸鈣	30%, 50°C	●			
氫氧化鈣	飽和溶液, 50°C	●			
鉻酸	1%, 20°C				●
冷凝液	90°C	●			
硫酸銅	不飽和溶液, 60°C				●
去離子 (完全脫鹽水)	50°C			●	
乙醇	100%, 20°C	●			
乙二醇/二甘醇	40%, 70°C	●	●	●	●
定影液	25°C				●
甲酸	5%, 20°C			●	

技術資料

Vertical Multistage Centrifugal In-line Pumps



STAIRS PUMPS

輸送液體	液體濃度溫度	SB (I)		SBN	
		EPDM	Viton	EPDM	Viton
果汁	50°C				●
甘油	50%, 50°C	●			
加熱油 (光)		●			●
液壓油	100%, 100°C		●		
異丙醇		●			
乳酸	10%, 20°C				●
亞油酸	100%, 20°C	●			
亞麻籽油	60°C		●		
酒	60°C				●
玉米油	80°C		●		
馬來酸	50%, 50°C				●
甲醇	100%, 20°C	●			
機油	100%, 80°C	●			
油 - 水 - 混合物	100°C		●		
草酸	1%, 20°C			●	
花生油	100%, 80°C		●		
磷酸	20%, 20°C			●	
聚乙二醇	90°C		●		●
聚乙二醇	40%, 70°C	●			
碳酸鉀	10%, 60°C	●			
碳酸氫鉀	10%, 60°C	●			
高錳酸鉀	5%, 20°C			●	
硫酸鉀	不飽和溶液, 80°C			●	
菜籽油	100%, 80°C		●		
矽油	100%		●		
碳酸鈉	10%, 60°C			●	
氫氧化鈉	25%, 50°C			●	
硝酸鈉	不飽和溶液, 80°C			●	
磷酸鈉	5%, 100°C			●	
硫酸鈉	10%, 60°C			●	
硫酸	5%, 25°C				●
水					
游泳池水	35°C	● SBI		●	
去離子水	50°C			●	
蒸餾水	50°C			●	
脫碳酸水				●	
軟水 (碳酸鈣含量少)				●	
加熱水				●	
鍋爐水				●	
純淨水				●	
沖洗水		● SBI		●	



Note

A series of horizontal dashed lines extending across the page, providing a template for handwritten notes.



宏奇泵浦工業有限公司

地址：611嘉義縣鹿草鄉三角村3-8號

電話：(05)3750488 傳真：(05)3752330

E-mail: stairs@stairs.com.tw

網站：www.stairs.com.tw